



Request for Proposals

RFP # 02

For the provision of

Public Utility Enterprise **DHP Knjazevac**

Contracting Entity:

**Serbia Energy Security Activity (Better Energy)**

Dubljsanska 8, Belgrade, Serbia

Funded by:

United States Agency for International Development (USAID)

Funded under:

Serbia Better Energy Activity

Prime Contract Number 7200AA19D00023/72016922F00001

**\*\*\*\*\* ETHICAL AND BUSINESS CONDUCT REQUIREMENTS \*\*\*\*\***

Chemonics is committed to integrity in procurement, and only selects suppliers based on objective business criteria such as price and technical merit. Chemonics expects suppliers to comply with our Standards of Business Conduct, available at <https://www.chemonics.com/our-approach/standards-business-conduct/>.

Chemonics does not tolerate fraud, collusion among offerors, falsified proposals/bids, bribery, or kickbacks. Any firm or individual violating these standards will be disqualified from this procurement, barred from future procurement opportunities, and may be reported to both USAID and the Office of the Inspector General.

Employees and agents of Chemonics are strictly prohibited from asking for or accepting any money, fee, commission, credit, gift, gratuity, object of value or compensation from current or potential vendors or suppliers in exchange for or as a reward for business. Employees and agents engaging in this conduct are subject to termination and will be reported to USAID and the Office of the Inspector General. In addition, Chemonics will inform USAID and the Office of the Inspector General of any supplier offers of money, fee, commission, credit, gift, gratuity, object of value or compensation to obtain business.

Offerors responding to this RFP must include the following as part of the proposal submission:

- Disclose any close, familial, or financial relationships with Chemonics or project staff. For example, if an offeror's cousin is employed by the project, the offeror must state this.
- Disclose any family or financial relationship with other offerors submitting proposals. For example, if the offeror's father owns a company that is submitting another proposal, the offeror must state this.
- Certify that the prices in the offer have been arrived at independently, without any consultation, communication, or agreement with any other offeror or competitor for the purpose of restricting competition.
- Certify that all information in the proposal and all supporting documentation are authentic and accurate.
- Certify understanding and agreement to Chemonics' prohibitions against fraud, bribery and kickbacks.

Please contact Daniel Berg at [dberg@chemonics.com](mailto:dberg@chemonics.com) with any questions or concerns regarding the above information or to report any potential violations. Potential violations may also be reported directly to Chemonics at [BusinessConduct@chemonics.com](mailto:BusinessConduct@chemonics.com) or by phone/Skype at 888.955.6881.

## **RFP Table of Contents**

List of Acronyms

### **Section I Instructions to Offerors**

- I.1 Introduction
- I.2 Chronological List of Proposal Events
- I.3 Offer Submission Requirements
- I.4 Eligibility Requirements
- I.5 Source of Funding, Authorized Geographic Code, and Source and Origin
- I.6 Validity Period
- I.7 Instructions for the Preparation of the Proposal
- I.8 Evaluation and Basis for Award
- I.9 Negotiations
- I.10 Terms of Subcontract
- I.11 Insurance and Services
- I.12 Privity

### **Section II Background, Scope of Work, Deliverables, and Deliverables Schedule**

- II.1. Background
- II.2. Scope of Work
- II.3. Deliverables
- II.4. Deliverables Schedule

### **Section III Firm Fixed Price Subcontract (Terms and Clauses)**

- Annex 1 Proposal Cover Letter
- Annex 2 Guide to Creating Financial Proposal and Sample Budget
- Annex 3 Required Certifications
- Annex 4 UEI and SAM Registration Guidance
- Annex 5 USAID Exemption Letter
- Annex 6 Terms of Reference with Concept design

## List of Acronyms

AIDAR	Agency for International Development (USAID) Acquisition Regulation
CFR	Code of Federal Regulations
CO	USAID Contracting Officer
COP	Chief of Party
COR	USAID Contracting Officer's Representative
CV	Curriculum Vitae
DBA	Defense Base Act
FAR	Federal Acquisition Regulations
MEDEVAC	Medical Evacuation
POC	Point of Contact
RFP	Request for Proposals
SAM	System for Award Management
SOW	Scope of work
UEI	Unique Entity Identifier
U.S.	United States
USAID	U.S. Agency for International Development
USAID/Serbia	USAID Mission in Serbia
USG	U.S. Government
VAT	Value Added Tax

## **Section I. Instructions to Offerors**

### **I.1. Introduction**

Chemonics, the Buyer, acting on behalf of the U.S. Agency for International Development (USAID) and the Serbia Energy Security Activity, under contract number 7200AA19D00023/72016922F00001 is soliciting offers from companies and organizations to submit proposals to participate with Serbia Energy Security Activity to improve energy efficiency in local heating supply to reduce gas consumption and Serbia's dependency on imported natural gas, by implementing pilot projects in district heating system.

Serbia Energy Security Activity (Better Energy) aims to address the lack of incentives and limited investments in renewable energy (RE) and energy efficiency (EE), and therefore address inefficient use of energy resources, a low level of renewables, and limited capacity by government stakeholders to design and implement strategies which support RE and EE expansion. The project will work with and incentivize local partners (both public and private sector) to adopt new products and/or practices. Through technical assistance and targeted grants, the project will encourage expanded use of new practices. The substations targeted by this project do not have the equipment that would enable optimal delivery of heat energy, meaning customer needs are not met and heat energy is wasted moving through the heating substation. In order to provide assistance to the DHP Knjazevac, to modernize and automatize outdated equipment the project will support them with preparation of necessary technical documentation.

**The subject of this RFP is: providing PROJECT DOCUMENTATION for MAIN PROJECT DESIGN according to the provided concept design for 16 thermal substations of DHP Knjazevac**

Offerors are invited to submit proposals in response to this RFP in accordance with **Section I Instructions to Offerors**, which will not be part of the subcontract. The instructions are intended to assist interested Offerors in the preparation of their offer. Any resulting subcontract will be guided by Sections II and III.

This RFP does not obligate Chemonics to execute a subcontract, nor does it commit Chemonics to pay any costs incurred in the preparation and submission of the proposals. Furthermore, Chemonics reserves the right to reject any and all offers, if such action is considered to be in the best interest of Chemonics.

Unless otherwise stated, the periods named in the RFP shall be consecutive calendar days.

### **I.2. Chronological List of Proposal Events**

The following calendar summarizes important dates in the solicitation process. Offerors must strictly follow these deadlines.

RFP announcement/published	22/06/2022
Deadline for written questions	27/06/2022
Answers provided to questions/clarifications	30/06/2022
Proposal due date	13/07/2022

The dates above may be modified at the sole discretion of Chemonics. Any changes will be published in an amendment to this RFP.

**Written Questions and Clarifications.** All questions or clarifications regarding this RFP must be in writing and submitted by email [procurement@serbiabetterenergy.com](mailto:procurement@serbiabetterenergy.com) no later than June 27, 2022. Questions and requests for clarification, and the responses thereto, will be circulated to all RFP recipients who have indicated an interest in this RFP. **Please indicate the RFP 02 -question, in the email Subject.**

Only written answers from Chemonics will be considered official and carry weight in the RFP process and subsequent evaluation. Any answers received outside the official channel, whether received verbally or in writing, from employees or representatives of Chemonics International, the Serbia Energy Security Activity project, or any other party, will not be considered official responses regarding this RFP.

**Proposal Submission Date.** All proposals must be received by the date and time and complying with the instructions as provided in Section I.3.

**Oral Presentations.** Chemonics reserves the option to have select offerors participate in oral presentations with the technical evaluation committee. Interviews may consist of oral presentations of offerors' proposed activities and approaches. Offerors should be prepared to give presentations to the technical evaluation committee at the Serbia Better Energy Security Activity office within 2 days of receiving notification.

**Subcontract Award (estimated).** Chemonics will select the proposal that offers the best value based upon the evaluation criteria stated in this RFP.

### **I.3. Offer Submission Requirements**

Offerors shall submit their offers electronically only.

Emailed offers must be received by the same time and date at the following address:

Serbia Energy Security Activity (Better Energy)  
Procurement  
Email subject: RFP 02 - submission  
[procurement@serbiabetterenergy.com](mailto:procurement@serbiabetterenergy.com)

Faxed offers will not be considered.

Offerors are responsible for ensuring that their offers are received in accordance with the instructions stated herein. Late offers may be considered at the discretion of Chemonics. Chemonics cannot guarantee that late offers will be considered.

Proposals must be submitted electronically only. Late offers will be considered at the discretion of Chemonics.

Separate technical and cost proposals must be submitted by email no later than the time and date specified in I.2. The proposals must be submitted to the point of contact designated in I.2.

The Offeror must submit the proposal electronically with up to 3 attachments (5 MB limit) per email compatible with MX Word, MS Excel, readable format, or Adobe Portable Document (PDF) format in a

Microsoft XP environment. Offerors must not submit zipped files. Those pages requiring original manual signatures should be scanned and sent in PDF format as an email attachment or signed by using e-signatures.

Technical proposals must not make reference to pricing data in order that the technical evaluation may be made strictly on the basis of technical merit.

#### **I.4. Eligibility Requirements**

To be determined responsive, an offer must include all of documents and sections included in I.4.A and I.4.B.

Chemonics anticipates issuing a subcontract to company or organization provided it is legally registered and recognized under the laws of the Republic of Serbia, and is in compliance with all applicable civil, fiscal, and other applicable regulations. Such a company or organization could include a private firm, non-profit, or university.

The award will be in the form of a firm fixed price subcontract (hereinafter referred to as “the subcontract”). The successful Offeror shall be required to adhere to the statement of work and terms and conditions of the subcontract, which are incorporated in Section III herein.

Companies and organizations that submit proposals in response to this RFP must meet the following requirements:

- (i) Companies or organizations, whether for-profit or non-profit, must be legally registered under the laws of Republic of Serbia upon award of the subcontract.
- (ii) Firms operated as commercial companies or other organizations or enterprises (including nonprofit organizations) in which foreign governments or their agents or agencies have a controlling interest are not eligible as suppliers of commodities and services.
- (iii) Companies or organizations must have a local presence in Serbia.
- (iv) Companies or organizations, whether for-profit or non-profit, shall be requested to provide a UEI number if selected to receive a subaward valued at USD\$30,000 or more, unless exempted in accordance with information certified in the Evidence of Responsibility form included in the required certifications in Annex 3.

Offerors may present their proposals as a member of a partnership with other companies or organizations. In such cases, the subcontract will be awarded to the lead company in the partnership. The leading company shall be responsible for compliance with all subcontract terms and conditions and making all partnership arrangements, including but not limited to division of labor, invoicing, etc., with the other company(ies). A legally registered partnership is not necessary for these purposes; however, the different organizations must be committed to work together in the fulfillment of the subcontract terms.

#### **I.5. Source of Funding, Authorized Geographic Code,**

- a) Any subcontract resulting from this RFP will be financed by USAID funding and will be subject

to U.S. Government and USAID regulations. All goods and services offered in response to this RFP or supplied under any resulting award must meet USAID Geographic **Code 935** in accordance with the United States Code of Federal Regulations (CFR), 22 CFR §228, available at: <http://www.gpo.gov/fdsys/pkg/CFR-2012-title22-vol1/pdf/CFR-2012-title22-vol1-part228.pdf>.

The cooperating country for this RFP is Republic of Serbia.

- b) Offerors may not offer or supply any products, commodities or related services that are manufactured or assembled in, shipped from, transported through, or otherwise involving any of the following countries: Cuba, Iran, North Korea, Syria. Related services include incidental services pertaining to any/all aspects of this work to be performed under a resulting contract (including transportation, fuel, lodging, meals, and communications expenses).
- c) Any and all items that are made by Huawei Technology Company, ZTE Corporation, Hytera Communications Corporation, Hangzhou Hikvision Digital Technology Company, Dahua Technology Company will not be accepted. If quotes include items from these entities, please note that they will be deemed not technically responsive and excluded from competition.
- d) The USG has implemented a blanket prohibition on providing direct government financing to international solar projects that source from suppliers that are the subject of a [withhold release order](#) (Hoshine Silicon Industry), on the Commerce Entity List, or otherwise sanctioned for their use of forced labor. The PRC energy companies that were added to the Commerce Entity List for their ties to forced labor are found below. NOTE: Offerors may not purchase from any of the Suppliers listed below without advance written approval from Chemonics/USAID.
  - Hoshine Silicon Industry (metallurgical grade silicon and silicon products) - also subject to a WRO
  - Xinjiang Daqo New Energy (polysilicon, wafers)
  - Xinjiang East Hope Nonferrous Metals (polysilicon, ingots, wafers)
  - Xinjiang GCL-New Energy Material (polysilicon, ingots, wafers, cells, modules)
  - Xinjiang Production and Construction Corps (state-owned paramilitary organization, electricity supplier)

This does not mean that all PRC-produced solar panels are immediately blocked. Currently, the restriction is just on any panels or products that are directly purchased using USG funds from any of those above companies. Should the purchase of any solar panels or components be required, Chemonics/USAID prior review and written approval is required.

## **I.6. Validity Period**

Offerors' proposals must remain valid for 90 calendar days after the proposal deadline.

## **I.7. Instructions for the Preparation of the Proposal**

### **1. Cover Letter**

The offeror shall use the cover letter provided in Annex 1 of this RFP, which confirms organizational information and consent to the validity of this proposal.

### **2. Technical Proposal**

The technical proposal shall comprise the parts below. Please note that the proposal must be responsive to the detailed information set out in Section II of this RFP, which provides the background, states the scope of work, describes the deliverables, and provides a deliverables schedule.

- Part 1: Technical Approach, Methodology and Detailed Work Plan. This part shall be between 3 and 5 pages long but may not exceed 5 pages.

Offerors may include the following:

- Corporate brochure or Link to official web site
  - Explanation of working approach for the required tasks (interpretation of objectives), demonstrating their experience and technical ability in task implementing.
  - Methodology and detailed work plan should be in accordance with the Concept design (Annex No. 6) and compliance with the DHP regulations
- Part 2: Management, Key Personnel, and Staffing Plan. This part shall be between 3 and 5 pages long but may not exceed 5 pages. CVs for key personnel may be included in an annex to the technical proposal and will not count against the page limit.

Offerors shall propose staff for the following key personnel positions necessary for the implementation of the scope of work:

- The offerors must have at least 1 a licensed Engineers or Consultant with minimum 10 years of experience.
  - The offerors must have one of the following experts must be ISO 50001 license holder
- Part 3: Corporate Capabilities, Experience, and Past Performance. This part shall be between 4 and 6 pages long but may not exceed 7 pages.

Part 3 must include a description of the company and organization, with appropriate reference to any parent company and subsidiaries. Offerors must include details demonstrating their experience and technical ability in implementing the technical approach/methodology and the detailed work plan.

Additionally, offerors must include 3 past performance references of similar work (under contracts or subcontracts) previously implemented as well as contact information for the companies for which such



work was completed. Contact information must include at a minimum: name of point of contact who can speak to the offeror’s performance, name and address of the company for which the work was performed, and email and phone number of the point of contact. Chemonics reserves the right to check additional references not provided by an offeror.

Furthermore, the offerors should be legally registered under the laws of the Republic of Serbia, minimum 10 years prior to award of subcontract and provide the Annual Financial Statements for the past 3 years (P&L and Balance sheet)

### 3. Cost Proposal

The cost proposal is used to determine which proposals represent the best value and serves as a basis of negotiation before award of a subcontract.

The price of the subcontract to be awarded will be an all-inclusive fixed price. Nevertheless, for the purpose of the proposal, offerors must provide a detailed budget showing major line items as well as a budget narrative. Please refer to Annex 2 for detailed instructions and a sample cost structure.

No profit, fees, taxes, or additional costs may be added after award. Because Serbia Better Energy Activity is a USAID funded project and is implemented under a bilateral agreement between the Government of Serbia and the U.S. Government, offerors must not include VAT and customs duties in their cost proposal. USAID has provided an exemption letter to this effect, a copy of which is included in Annex 5.

## I.8 Evaluation and Basis for Award

This RFP will use the tradeoff process to determine best value as set forth in FAR 15.101-1. That means that each proposal will be evaluated and scored against the evaluation criteria and evaluation sub-criteria, which are stated in the table below. Chemonics will award a subcontract to the offeror whose proposal represents the best value to Chemonics and the Serbia Better Energy Activity project. Chemonics may award to a higher priced offeror if a determination is made that the higher technical evaluation of that offeror merits the additional cost/price.

Evaluation points will not be awarded for cost, but for overall evaluation purposes of this RFP, technical evaluation factors other than cost, when combined, are considered approximately equal to cost factors. Cost will primarily be evaluated for realism and reasonableness. If technical scores are determined to be nearly equal, cost will become the determining factor.

In evaluating proposals, Chemonics will use the following evaluation criteria and sub-criteria:

Evaluation Criteria	Evaluation Sub-criteria	Maximum Points
Technical Approach, Methodology, and Detailed Work Plan		
	Technical know-how – Chemonics will assess whether the proposal explains,	20 points

	understands, and responds to the objectives of the project as stated in the Scope of Work	
	Approach and Methodology – Chemonics will assess whether the proposed program approach and detailed activities and suggested timeline fulfill the requirements of executing the Scope of Work effectively and efficiently?	20 points
	Sector Knowledge – Chemonics will assess whether the proposal demonstrates the offeror’s knowledge related to technical sectors required by the SOW?	10 points
<b>Total Points – Technical Approach</b>		<b>50 points</b>
<b>Management, Key Personnel, and Staffing Plan</b>		
	Personnel Qualifications – Chemonics will evaluate the curriculum vitae (CVs) of the proposed team members and evaluate if the Offeror has the license, standards, experience, and capabilities carry out the Scope of Work?	30 points
<b>Total Points – Management</b>		<b>30 points</b>
<b>Corporate Capabilities, Experience, and Past Performance</b>		
	Company Background and Experience – Chemonics will evaluate whether the company experience is relevant to the project Scope of Work?	10 points
	Chemonics will assess the past performance of the Offerors by contacting three references who may indicate the Offeror's past performance for projects of similar size and scope	10 points
<b>Total Points – Corporate Capabilities</b>		<b>20 points</b>
<b>Total Points</b>		<b>100 points</b>

## I.9 Negotiations

Best offer proposals are requested. It is anticipated that a subcontract will be awarded solely on the basis of the original offers received. However, Chemonics reserves the right to conduct discussions, negotiations and/or request clarifications prior to awarding a subcontract. Furthermore, Chemonics reserves the right to conduct a competitive range and to limit the number of offerors in the competitive range to permit an efficient evaluation environment among the most highly-rated proposals. Highest-rated offerors, as

determined by the technical evaluation committee, may be asked to submit their best prices or technical responses during a competitive range. At the sole discretion of Chemonics, offerors may be requested to conduct oral presentations. If deemed an opportunity, Chemonics reserves the right to make separate awards per component or to make no award at all.

### **I.10 Terms of Subcontract**

This is a request for proposals only and in no way obligates Chemonics to award a subcontract. In the event of subcontract negotiations, any resulting subcontract will be subject to and governed by the terms and clauses detailed in Section III. Chemonics will use the template shown in section III to finalize the subcontract. Terms and clauses are not subject to negotiation. By submitting a proposal, offerors certify that they understand and agree to all of the terms and clauses contained in section III.

### **I.11 Insurance and Services**

Within two weeks of signature of this subcontract, the Offeror shall procure and maintain in force, on all its operations, insurance in accordance with the charts listed below. The policies of insurance shall be in such form and shall be issued by such company or companies as may be satisfactory to Chemonics. Upon request from Chemonics, the Supplier shall furnish Chemonics with certificates of insurance from the insuring companies which shall specify the effective dates of the policies, the limits of liabilities there under, and contain a provision that the said insurance will not be canceled except upon thirty (30) days' notice in writing to Chemonics. The Supplier shall not cancel any policies of insurance required hereunder either before or after completion of the work without written consent of Chemonics. Note DBA is reimbursable to the Offeror.

#### **DEFENSE BASE ACT (DBA) INSURANCE**

a) FAR 52.228-3 WORKER'S COMPENSATION INSURANCE (DEFENSE BASE ACT INSURANCE) (Jul 2014) [Updated by AAPD 05-05 — 02/12/04]

The Subcontractor shall (a) provide, before commencing performance under this Subcontract, such workers' compensation, or security as the Defense Base Act (DBA) (42 U.S.C. 1651, et seq.) requires and (b) continue to maintain it until performance is completed. The Subcontractor shall insert, in all lower-tier subcontracts authorized by Chemonics under this Subcontract to which the Defense Base Act applies, a clause like this clause imposing upon those lower-tier subcontractors this requirement to comply with the Defense Base Act. DBA insurance provides critical protection and limits on liability. The Subcontractor shall provide a proof of DBA insurance coverage to Chemonics upon request. Chemonics will verify coverage for, at least, projects in high-risk environments and where Chemonics may be providing security.

(b) AIDAR 752.228-3 WORKERS' COMPENSATION (DEFENSE BASE ACT) [Updated by AAPD 05-05 — 02/12/04] As prescribed in AIDAR 728.308, the following supplemental coverage is to be added to the clause specified in FAR 52.228-3.

(1) The Subcontractor agrees to procure DBA insurance pursuant to the terms of the contract between USAID and USAID's DBA insurance carrier unless the Subcontractor has a DBA self-insurance program approved by the U.S. Department of Labor or has an approved retrospective rating agreement for DBA.

(2) If USAID or Subcontractor has secured a waiver of DBA coverage (See AIDAR 728.305-70(a)) for Subcontractor's employees who are not citizens of, residents of, or hired in the United States, the Subcontractor agrees to provide such employees with worker's compensation benefits as required by the laws of the country in which the employees are working, or by the laws of the employee's native country, whichever offers greater benefits.

(3) The Subcontractor further agrees to insert in all lower-tier subcontracts hereunder to which the DBA is applicable a clause similar to this clause, including the sentence, imposing on all lower-tier subcontractors authorized by Chemonics a like requirement to provide overseas workmen's compensation insurance coverage and obtain DBA coverage under the USAID requirements contract.

(4) USAID's DBA insurance carrier. Pursuant to the clause of this Subcontract entitled "Worker's Compensation Insurance (Defense Base Act)" (AIDAR 752.228 03), the Subcontractor shall obtain DBA coverage from USAID's current insurance carrier for such insurance. This insurance carrier as of the effective date of this Subcontract is AON Risk Insurance Services West, Inc. Address is: AON, 2033 N. Main St., Suite 760, Walnut Creek, CA 94596-3722. Point of contact is Fred Robinson: (o) 925-951-1856, fax: 925-951-1890, E-Mail: Fred.Robinson@aon.com. Subcontractor must apply for coverage directly to AON Risk Insurance Services Inc., the agent for AWAC DBA Insurance. For instructions on the required application form and submission requirements, please refer to AAPD 17-01. Pursuant to AIDAR 752.228-70, medical evacuation is a separate insurance requirement for overseas performance of USAID funded subcontracts; the Defense Base Act insurance does not provide coverage for medical evacuation. The costs of DBA insurance are allowable and reimbursable as a direct cost to this Subcontract.

(c) AIDAR 752.228-7 INSURANCE ON PRIVATE AUTOMOBILES Pursuant to the clause of this Subcontract entitled "Insurance Liability to Third Persons" (AIDAR 752.228-07), if the Subcontractor or any of its employees, consultants, or their dependents transport or cause to be transported (whether or not at Subcontract expense) privately owned automobiles to the Cooperating Country, or if any of them purchase an automobile within the Cooperating Country, the Subcontractor shall, during the period of this Subcontract, ensure that all such automobiles during such ownership within the Cooperating Country will be covered by a paid-up insurance policy issued by a reliable company providing minimum coverage of US\$10,000/US\$20,000 for injury to persons and US\$5,000 for property damage, or such other minimum coverages as may be set by the cognizant Mission Director, payable in U.S. dollars or its equivalent in the currency of the Cooperating Country. The premium costs of such insurance shall not be a reimbursable cost under this Subcontract.

(d) AIDAR 752.228-70 Medical Evacuation Services (MEDEVAC) Services (July 2007) [Updated by AAPD 06-01].

(1) The Subcontractor shall provide MEDEVAC service coverage to all U.S. citizen, U.S. resident alien, and Third Country National employees and their authorized dependents (hereinafter "individual") while overseas under a USAID-financed direct contract. Chemonics will reimburse reasonable, allowable, and allocable costs for MEDEVAC service coverage incurred under this Subcontract. The USAID Contracting Officer through Chemonics will determine the reasonableness, allowability, and allocability of the costs based on the applicable cost principles and in accordance with cost accounting standards.

(2) Exceptions: (i) The Subcontractor is not required to provide MEDEVAC insurance to eligible employees and their dependents with a health program that includes sufficient MEDEVAC

coverage as approved by Chemonics. (ii) The USAID Mission Director through Chemonics, may make a written determination to waive the requirement for such coverage. The determination must be based on findings that the quality of local medical services or other circumstances obviate the need for such coverage for eligible employees and their dependents located at post.

(3) If authorized to issue lower-tier subcontracts, the Subcontractor shall insert a clause similar to this clause in all lower-tier subcontracts that require performance by Subcontractor employees

e) In addition to the foregoing insurance requirements, the Supplier shall, as a minimum, obtain the following insurance in form and substance satisfactory to Chemonics that are covered by the standard fixed rates in Section 3.

TYPE	MINIMUM LIMIT
(a) Defense Base Act or equivalent for waived nationals per FAR 52.228-3 and 52.228-4. The coverage shall extend to Employers Liability for bodily injury, death, and for occupational disease.	As required by DBA
(b) Comprehensive General Liability Each Occurrence Combined Single Limit for Personal Injury and/or Property Damage.	\$1,000,000 \$2,000,000
(c) Automobile Liability Combined Single Limit each occurrence	As per AIDAR 752.228-7 and \$1,000,000
(d) Other Required Insurance- Umbrella Insurance additive to (b) and (c) above	\$1,000,000/ \$2,000,000

## I. 12 Privity

By submitting a response to this request for proposals, offerors understand that USAID is NOT a party to this solicitation and the offeror agrees that any protest hereunder must be presented—in writing with full explanations—to Chemonics International for consideration, as USAID will not consider protests made to it under USAID-financed subcontracts. Chemonics, at its sole discretion, will make a final decision on the protest for this procurement

## **Section II Background, Scope of Work, Deliverables, and Deliverables Schedule**

### **II.1. Background**

DHP Knjazevac has 16 thermal substations that supply MABs. Detailed analysis of each of the 16 substations determined that each heat substation was equipped with dilapidated and defective mechanical and electrical elements (exchanger, circulating pumps, valves) and lacked measuring and control equipment and equipment for communication with the command center. Based on the research including the analysis of the entire district heating system of the DHP Knjazevac, which as a result provided efficiency indicators of all elements of the district heating system, it was concluded that in addition to switching from fuel oil to biomass, it is necessary to automate and optimize all 16 thermal heating substations

Preparation of the project documentation for Main project design for the 16 substation - subject of this RFP, is related to anticipated in kind grant to the DHP of the municipality of Knjazevac. It will satisfy the needs of the end users and at the same time define the DHP as a leading company within the energy field.

### **II.2. Scope of Work**

According to provided terms of reference - Concept design (Annex 6), the offeror should provide **PROJECT DOCUMENTATION for MAIN PROJECT DESIGN for 16 thermal substations of DHP Knjazevac**

The Terms of Reference includes the preparation of technical project documentation for the entire mechanical and electrical phase of DHP Knjazevac

The Project must contain:

1. Mechanical part must include all the necessary mechanical and technical details related to thermo-mechanical armature of the heating substations.
2. Electrical energy and automation part must include the substation power supply system, all the circulation pumps, measuring, control and communication, describing equipment necessary for the operation of the heating substation.
3. Part containing description of work and SCADA solution must include a detailed description of the SCADA system, control algorithms and communication equipment for remote connection of the central SCADA server with the heating substations.

Therefore, the technical project documentation that is the subject of procurement must be done at the level of Main design project and must contain all Detailed Design parts:

1. General part of the project
2. Numerical documentation and calculations
3. Graphic documentation
4. Bill of quantities

### II.3. Deliverables

The successful offeror shall deliver to Chemonics the following deliverables, in accordance with the schedule set forth in II.4 below.

Deliverable No. 1: **PROJECT DOCUMENTATION for MAIN PROJECT DESIGN according to the provided concept design for 16 thermal substations of DHP Knjazevac**

The successful offeror must provide project documentation in accordance with regulations of DHP and it must be done at the level of Detailed Design.

### II.4. Deliverables Schedule

The successful offeror shall submit the deliverables described above in accordance with the following deliverables schedule:

<b>Deliverable Number</b>	<b>Deliverable Name</b>	<b>Due Date</b>
1.	Project documentation for Execution design for 16 thermal substations of DHP Knjazevac	November 01 <sup>st</sup> 2022

\*Deliverable numbers and names refer to those fully described in II.3 above.

### Section III Firm Fixed Price Subcontract (Terms and Clauses)

#### Subcontract Fixed Price, Invoicing and Payment

##### D.1. Subcontract Fixed Price

As consideration for the delivery of all of the products and/or services stipulated in Section A., Chemonics will pay the Subcontractor a total of **US\$ XX,XXX** (Amount must be denominated in local currency if a local subcontract) . This figure represents the total price of this subcontract and is fixed for the period of performance outlined in Section C., Period of Performance. Chemonics will pay the total price through a series of installment payments. Chemonics will make each payment subject to Section D.3, below, after Subcontractor's completion of the corresponding deliverable indicated in the following table:

Installment Number and Amount	Corresponding Deliverable Number(s) and Name(s)*
1. <b>\$XX,XXX</b>	1. (Deliverable No. 1 Name)

\*Deliverable numbers and names refer to those fully described in Section A.3, above.

##### D.2. Invoicing

Upon technical acceptance of the contract deliverables described in Section A., Background, Scope of Work, Deliverables and Deliverables Schedule, by the Chemonics representative identified herein, the Subcontractor shall submit an original invoice to (insert project name) for payment. The invoice shall be sent to the attention of (insert name and designation of person who will receive invoices) and shall include the following information: a) subcontract number, b) deliverables delivered and accepted, c) total amount due in (choose either US dollars or specify a local currency if this is a local subcontract) , per Section D.1., above; and d) payment information corresponding to the authorized account listed in D.3, below.

##### D.3. Payment Account Information

Chemonics shall remit payment corresponding to approved, complete invoices submitted in accordance with the terms herein payable to the Subcontractor via check sent to the Subcontractor's official address or to the following authorized account:

Account name: (INSERT Account name provided by the Subcontractor)

Bank name: (INSERT Subcontractor's bank name)

Bank address or branch location: (INSERT Subcontractor's bank address or branch location)

Account number: (INSERT Subcontractor's bank account SWIFT and IBAN reference as applicable)

##### D.4. Payment

Chemonics will pay the Subcontractor's invoice within thirty (30) business days after both a) Chemonics' approval of the Subcontractor's deliverables, and b) Chemonics' receipt of the Subcontractor's invoice. Payment will be made in (choose either US dollars or specify a local currency if this is a local subcontract) , paid to the account specified in Section D.3.

#### Branding Policy



The Subcontractor shall comply with the requirements of the USAID “Graphic Standard Manual” available at [www.usaid.gov/branding](http://www.usaid.gov/branding), or any successor branding policy, and the Project specific branding implementation and marking plan, which shall be conveyed to the Subcontractor by Chemonics in writing.

Authorized Geographic Code; Source and Nationality Requirement [AIDAR 752.225-70 (Feb 2012) as altered]

(a) The authorized geographic code for procurement of goods and services under this subcontract is **{insert applicable geographic code}**.

(b) Except as may be specifically approved by Chemonics, the Subcontractor must procure all commodities (e.g., equipment, materials, vehicles, supplies) and services (including commodity transportation services) in accordance with the requirements at 22 CFR Part 228 —Rules on Procurement of Commodities and Services Financed by USAID Federal Program Funds. Guidance on eligibility of specific goods or services may be obtained from Chemonics.

(c) Ineligible goods and services. The Subcontractor shall not procure any of the following goods or services under this subcontract:

- (1) Military equipment
- (2) Surveillance equipment
- (3) Commodities and services for support of police and other law enforcement activities
- (4) Abortion equipment and services
- (5) Luxury goods and gambling equipment, or
- (6) Weather modification equipment.

(d) Restricted goods. The Subcontractor shall not procure any of the following goods or services without the prior written approval of USAID obtained through Chemonics:

- (1) Agricultural commodities,
- (2) Motor vehicles,
- (3) Pharmaceuticals and contraceptive items
- (4) Pesticides,
- (5) Fertilizer,
- (6) Used equipment, or
- (7) U.S. government-owned excess property.

If Chemonics determines that the Subcontractor has procured any of these specific restricted this subcontract without the prior written authorization of USAID through Chemonics and has received payment for such purposes, Chemonics may require the Subcontractor to refund the entire amount of the purchase.

(e) The USG has implemented a blanket prohibition on providing direct government financing to international solar projects that source from suppliers that are the subject of a [withhold release order](#) (Hoshine Silicon Industry), on the Commerce Entity List, or otherwise sanctioned for their use of forced labor. The PRC energy companies that were added to the Commerce Entity List for their ties to forced labor are found below. NOTE: the subcontractor may not purchase from any of the Suppliers listed below without advance written approval from Chemonics/USAID.

- Hoshine Silicon Industry (metallurgical grade silicon and silicon products) - also subject to a WRO

- Xinjiang Daqo New Energy (polysilicon, wafers)
- Xinjiang East Hope Nonferrous Metals (polysilicon, ingots, wafers)
- Xinjiang GCL-New Energy Material (polysilicon, ingots, wafers, cells, modules)
- Xinjiang Production and Construction Corps (state-owned paramilitary organization, electricity supplier).

This does not mean that all PRC-produced solar panels are immediately blocked. Currently, the restriction is just on any panels or products that are directly purchased using USG funds from any of the above companies. Should the purchase of any solar panels or components be required, Chemonics/USAID prior review and written approval is required.

### Intellectual Property Rights

(a) Subcontractor warrants that the Work performed or delivered under this Subcontract will not infringe or otherwise violate the intellectual property rights of any third party in the United States or any foreign country. Except to the extent that the U.S. Government assumes liability therefor, Subcontractor shall defend, indemnify, and hold harmless Chemonics and its clients from and against any claims, damages, losses, costs, and expenses, including reasonable attorneys' fees, arising out of any action by a third party that is based upon a claim that the Work performed or delivered under this Subcontract infringes or otherwise violates the intellectual property rights of any person or entity. This indemnity and hold harmless shall not be considered an allowable cost under any provisions of this Subcontract except with regard to allowable insurance costs.

(b) Subcontractor's obligation to defend, indemnify, and hold harmless Chemonics and its customers under Paragraph (a) above shall not apply to the extent FAR 52.227-1 "Authorization and Consent" applies to Chemonics' Prime Contract for infringement of a U.S. patent and Chemonics and its clients are not subject to any actions for claims, damages, losses, costs, and expenses, including reasonable attorneys' fees by a third party.

(c) In addition to any other allocation of rights in data and inventions set forth in this agreement, Subcontractor agrees that Chemonics, in the performance of its prime or higher tier contract obligations (including obligations of follow-on contracts or contracts for subsequent phases of the same program), shall have under this agreement an unlimited, irrevocable, paid-up, royalty-free right to make, have made, sell, offer for sale, use, execute, reproduce, display, perform, distribute (internally or externally) copies of, and prepare derivative works, and authorize others to do any, some or all of the foregoing, any and all, inventions, discoveries, improvements, mask works and patents as well as any and all data, copyrights, reports, and works of authorship, conceived, developed, generated or delivered in performance of this Contract.

(d) The tangible medium storing all reports, memoranda or other materials in written form including machine readable form, prepared by Subcontractor and furnished to Chemonics pursuant to this Subcontract shall become the sole property of Chemonics.

### Indemnity and Subcontractor Waiver of Benefits

The Subcontractor shall defend, indemnify, and hold harmless Chemonics from any loss, damage, liability, claims, demands, suits, or judgments ("Claims") including any reasonable attorney's fees, and costs, as a

result of any damage or injury to Chemonics or its employees, directors, officers, or agents, or properties, or for any injury to third persons (including, but not limited to Claims by Subcontractor's employees, directors, officers or agents) or their property which is directly or indirectly caused by the negligence, willful misconduct, breach of this Subcontract, or violation of statutory duties of Subcontractor, or its employees, officers, directors, or agents, arising out of or in connection with the performance of this Subcontract unless such Claim is caused by, or resulting from, a material breach of this Subcontract by Chemonics.

#### Compliance with Applicable Laws and Regulations

(a) The Subcontractor shall perform all work, and comply in all respects, with applicable laws, ordinances, codes, regulations, and other authoritative rules of the United States and its political subdivisions and with the standards of relevant licensing boards and professional associations. The Subcontractor shall also comply with the applicable USAID regulations governing this subcontract, which are incorporated by reference into this subcontract, and appear in Section Z, Clauses Incorporated by Reference.

(b) This contract shall be governed and construed under the laws of the District of Columbia, except that subcontract provisions and requirements that are based on government contract laws, regulations, or Federal Acquisition Regulation clauses shall be construed in accordance with the federal common law of Government Contracts as represented by decisions of the Federal Courts, and the Armed Services and Civilian Boards of Contract Appeals.

(c) The Subcontractor shall further undertake to perform the services hereunder in accordance with the highest standards of professional and ethical competence and integrity in Subcontractor's industry and to ensure that Subcontractor's employees assigned to perform any services under this subcontract will conduct themselves in a manner consistent therewith.

1. The Subcontractor shall exercise due diligence to prevent and detect criminal conduct and otherwise promote an organizational culture that encourages ethical conduct and a commitment to compliance with law.
2. The Subcontractor shall timely disclose, in writing, to Chemonics and the USAID Office of the Inspector General (OIG), whenever, in connection with this subcontract, or any Order issued hereunder, if applicable, the Subcontractor has credible evidence that a principal, employee, agent, or subcontractor of the Subcontractor has committed a violation of the provisions against fraud, conflict of interest, bribery or gratuity, or false claims found in this subcontract.
3. The Subcontractor shall refer to FAR 52.203-13 Contractor Code of Business Ethics and Conduct incorporated by reference herein for applicability of additional requirements.

#### Privity of Contract and Communications

The Subcontractor shall not communicate with Chemonics' client in connection with this Subcontract, except as expressly permitted, in writing, by Chemonics. All approvals required from USAID shall be obtained through Chemonics.

This provision does not prohibit the Subcontractor from communicating with the client with respect to:

- (a) matters the Subcontractor is required by law to communicate to the U.S. Government;
- (b) an ethics or anti-corruption matter;
- (c) any matter for which this Subcontract, including a FAR or AIDAR clause is included in this Subcontract, provides for direct communication by the Subcontractor to the U.S. Government; or
- (d) if Subcontractor is a U.S. small business concern, any material matter pertaining to payment or utilization.

Protecting Chemonics' Interests when Subcontractor is Named on Suspected Terrorists or Blocked Individuals Lists, Ineligible to Receive USAID Funding, or Suspended, Debarred or Excluded from Receiving Federal Funds

In addition to any other rights provided under this subcontract, it is further understood and agreed that Chemonics shall be at liberty to terminate this subcontract immediately at any time following any of the following conditions:

- (a) the Subcontractor is named on any list of suspected terrorists or blocked individuals maintained by the U.S. Government, including but not limited to (a) the Annex to Executive Order No. 13224 (2001) (Executive Order Blocking Property and Prohibiting Transactions with Persons Who Commit, Threaten to Commit, or Support Terrorism), or (b) the List of Specially Designated Nationals and Blocked persons maintained by the Office of Foreign Assets Control of the U.S. Department of the Treasury;
- (b) USAID determines that the Subcontractor is ineligible to receive USAID funding pursuant to U.S. laws and regulations; or
- (c) the Subcontractor is identified on the U.S. Government's Excluded Party List System, or successor listing, as being suspended, debarred, or excluded from receiving federal awards or assistance.

Notwithstanding any other provision of the Subcontract, upon such termination the Subcontractor shall have no right to receive any further payments.

Governing Law and Resolution of Disputes

(a) *Governing law.* This Subcontract shall be governed and construed under the laws of the District of Columbia, except that subcontract provisions and requirements that are based on government contract laws, regulations, or Federal Acquisition Regulation clauses shall be construed in accordance with the federal common law of Government Contracts as represented by decisions of the Federal Courts, and the Armed Services and Civilian Boards of Contract Appeals.

(b) *Disputes based on Client Actions.*

(1) Any decision of the Government under the Prime Contract, if binding on Chemonics, shall also bind the Subcontractor to the extent that it relates to this Subcontract, provided that Chemonics shall have promptly notified the Subcontractor of such decision and, if requested by Subcontractor, shall have brought suit or filed claim, as appropriate against the Government, or, in alternative, agreed to sponsor Subcontractor's suit or claim. A final judgment in any such suit or final disposition of such claim shall be conclusive upon the Subcontractor.

(2) For any action brought, or sponsored, by Chemonics on behalf of the Subcontractor pursuant to this clause, the Subcontractor agrees to indemnify and hold Chemonics harmless from all costs and expenses incurred by Chemonics in prosecuting or sponsoring any such appeal.

(c) *Other Disputes.* All disputes not covered under subparagraph (b) above shall be resolved by arbitration administered by the American Arbitration Association in accordance with its Commercial Arbitration Rules. Arbitration shall be conducted in Washington, DC. Arbitrators shall be empowered to award only direct damages consistent with the terms of this Agreement. Each party shall bear its own costs of arbitration, including attorneys' and experts' fees. An arbitration decision shall be final and judgment may be entered upon it in accordance with applicable law in any court having jurisdiction.

(d) *Duty to Continue to Perform.* Notwithstanding any such dispute, the Subcontractor shall proceed diligently with performance under this Subcontract in accordance with the Contractor's directions.

(e) *Limitations.* Chemonics' entire liability for claims arising from or related to this Subcontract will in no event exceed the total subcontract fixed price. Except for indemnification obligations, neither the Subcontractor or Chemonics will have any liability arising from or related to this Subcontract for (i) special, incidental, exemplary, or indirect damages, or for any economic consequential damages, or (ii) lost profits, business, revenue, goodwill or anticipated savings, even if any of the foregoing is foreseeable or even if a party has been advised of the possibility of such damages.

The Subcontractor acknowledges and agrees that it has no direct action against the U.S. Government or USAID for any claims arising under this Subcontract.

#### Set-Off Clause

Chemonics reserves the right of set-off against amounts payable to Subcontractor under this Subcontract or any other agreement the amount of any claim or refunds Chemonics may have against Subcontractor.

#### Assignment and Delegation

This Subcontract agreement may not be assigned or delegated, in whole or in part, by the Subcontractor without the written consent of Chemonics. Absent such consent, any assignment is void.

#### Organizational Conflicts of Interest

It is understood and agreed that some of the work performed under this subcontract may place the Subcontractor or its personnel in the position of having an organizational conflict of interest. Such an organizational conflict of interest may impair the objectivity of the Subcontractor or its personnel in performing the work. To preclude or mitigate any potential conflicts of interest, Subcontractor agrees not to undertake any activity which may result in an organizational conflict of interest without first notifying Chemonics of such potential conflict of interest and receiving Chemonics written approval to undertake such activities.

#### Gratuities and Anti-Kickback

(a) Subcontractor shall not offer or give a kickback or gratuity (in the form of entertainment, gifts, or otherwise) for the purpose of obtaining or rewarding favorable treatment as a Chemonics supplier.

(b) By accepting this Subcontract, Subcontractor certifies and represents that it has not made or solicited and will not make or solicit kickbacks in violation of FAR 52.203-7 or the Anti-Kickback Act of 1986 (41 USC 51-58), both of which are incorporated herein by this specific reference, except that paragraph (c)(1) of FAR 52.203-7 shall not apply.

#### Terrorist Financing Prohibition/ Executive Order 13224

The Subcontractor (including its employees, consultants and agents) by entering into this subcontract certifies that it does not engage, support or finance individuals and/or organizations associated with terrorism. The Subcontractor is reminded that U.S. Executive Orders and U.S. law prohibits transactions with, and the provision of resources and support to, individuals and organizations associated with terrorism. A list of entities and individuals subject to restrictions, prohibitions and sanctions can be found at the web site of the Department of Treasury's Office of Foreign Assets Control (OFAC), at <http://treasury.gov/ofac>. It is the legal responsibility of the Subcontractor to ensure compliance with the Executive Order 13224 and other U.S. laws prohibiting terrorist financing. This provision must be included in all subcontracts or subawards issued under this subcontract.

#### Restrictions on Certain Foreign Purchases (FAR 52.225-13)

Except as authorized by the Department of Treasury's Office of Foreign Assets Control (OFAC), the Subcontractor shall not acquire for its use in the performance of this subcontract, any supplies or services if any proclamation, U.S. Executive Order, U.S. statute, or OFAC's implementing regulations (31 CFR Chapter V), would prohibit such a transaction by a U.S. person, as defined by law.

Except as authorized by OFAC, most transactions involving Cuba, Iran, North Korea, and Syria are prohibited, including importing/exporting to/from the United States, engaging in financial transactions, or facilitating any prohibited transactions by third parties. Lists of entities and individuals subject to economic sanctions – which are updated routinely - are included in OFAC's List of Specially Designated Nationals and Blocked Persons at <https://home.treasury.gov/policy-issues/financial-sanctions/specially-designated-nationals-and-blocked-persons-list-sdn-human-readable-lists>.

It is the Subcontractor's responsibility to remain informed as to sanctioned parties and to ensure compliance with all relevant U.S. sanctions and trade restrictions. More information about these restrictions, as well as updates, is available in the OFAC's regulations at 31 CFR Chapter V and/or on OFAC's website at <https://home.treasury.gov/policy-issues/office-of-foreign-assets-control-sanctions-programs-and-information>.

The Subcontractor shall insert this clause, including this paragraph, in all subcontracts and subawards issued under this subcontract.

#### Compliance with U.S. Export Laws

Subcontractor warrants and agrees to comply with all U.S. export laws and regulations and other applicable U.S. law and regulations, including but not limited to: (i) the Arms Export Control Act (AECA), 22 U.S.C. 2778 and 2779; (ii) Trading with the Enemy Act (TWEA), 50 U.S.C. App. §§ 1-44; (iii) International Traffic in Arms Regulations (ITAR), 22 C.F.R. Parts 120-130.; (iv) Export Administration Act (EAA) of 1979 and the Export Administration Regulations (EAR) 15 C.F.R. Parts 730-774, (including the EAR anti-

boycott provision); (v) the International Emergency Economic Powers Act (IEEPA), 50 U.S.C. 1701-1706 and Executive Orders of the President under IEEPA, 50 U.S.C. app. §§ 2401-2420; (vi) Office of Foreign Asset Controls (OFAC) Regulations, 31 C.F.R. Parts 500-598; and (vii) other applicable U.S. laws and regulations.

As required, subject to Chemonics' prior approval for all exports or imports under the Subcontract, Subcontractor shall determine any export license, reporting, filing or other requirements, obtain any export license or other official authorization, and carry out any customs formalities for the export of goods or services. Subcontractor agrees to cooperate in providing any reports, authorizations, or other documentation related to export compliance requested by Chemonics. Subcontractor agrees to indemnify, hold harmless and defend Chemonics for any losses, liabilities and claims, including as penalties or fines as a result of any regulatory action taken against Chemonics as a result of Subcontractor's non-compliance with this provision.

#### Compliance with U.S. Anti-Corruption Regulations

Subcontractor represents and warrants that it shall comply fully with the anti-bribery provisions of the U.S. Foreign Corrupt Practices Act, as amended ("FCPA"), as well as the a) UN Convention against Corruption (UNCAC), b) OECD Convention on the Bribery of Foreign Public Officials (OECD Convention); and c) any other applicable local anti-corruption laws, rules, and regulations if any part of this subcontract will be performed outside of the United States of America. Specifically, Subcontractor understands and agrees that it shall be unlawful for the Subcontractor and/or any officer, director, employee or agent of the Subcontractor to make any kind of offer, payment, promise to pay, or authorization of the payment of any money, or offer, gift, promise to give, or authorization of the giving of anything of value to:

- (a) *any foreign official* (or foreign political party) for purposes of either influencing any act or decision of such foreign official in his official capacity, or inducing such foreign official to do or omit to do any act in violation of the lawful duty of such official, or securing any improper advantage, or inducing such foreign official to use his influence with a foreign government, or instrumentality thereof, to affect or influence any act or decision of such government or instrumentality in order to assist such person in obtaining or retaining business for or with, or directing business to any person; or
- (b) *any person*, while knowing that all or a portion of such money or thing of value will be offered, given, or promised, directly or indirectly, to any foreign official (or foreign political party), or to any candidate for foreign political office, for any of the prohibited purposes described above.

For purposes of this Subcontract "foreign official" means any appointed, elected, or honorary official or employee of a) a foreign government (or if this Subcontract is to be performed outside the United States than of the Host Country) or political party, or b) of a public international organization, or any person acting in an official capacity for or on behalf of any such government or department, agency, or instrumentality, or for or on behalf of any such public international organization (e.g., the UN, DFID, or WHO, or the World Bank).

For purposes of this Article, the "government" includes any agency, department, embassy, or other governmental entity, and any company or other entity owned or controlled by the government.

#### Subcontractor Performance Standards

(a) Subcontractor agrees to provide the services required hereunder in accordance with the requirements set forth in this Subcontract. Subcontractor undertakes to perform the services hereunder in accordance with the highest standards of professional and ethical competence and integrity in Subcontractor's industry and to ensure that employees assigned to perform any services under this subcontract will conduct themselves in a manner consistent therewith. The services will be rendered by Subcontractor: (1) in an efficient, safe, courteous, and businesslike manner; (2) in accordance with any specific instructions issued from time to time by Chemonics; and (3) to the extent consistent with items (1) and (2), as economically as sound business judgment warrants. Subcontractor shall provide the services of qualified personnel through all stages of this subcontract. Subcontractor represents and warrants that it is in compliance with all the applicable laws of the United States and any other Jurisdiction in which the services shall be performed. Subcontractor shall perform the services as an independent Subcontractor with the general guidance of Chemonics. The Subcontractor's employees shall not act as agents or employees of Chemonics.

(b) Chemonics reserves the right to request the replacement of Subcontractor personnel and may terminate the subcontract due to nonperformance by the Subcontractor.

(c) Chemonics will use a variety of mechanisms to stay abreast of the Subcontractor's performance under the subcontract, and of general progress toward attainment of the subcontract objectives. These may include:

- 1) Business meetings between the subcontract team, Chemonics and/or USAID
- 2) Feedback from key partners
- 3) Site visits by Chemonics personnel
- 4) Meetings to review and assess periodic work plans and progress reports
- 5) Reports

#### Subcontractor Employee Whistleblower Rights

This Subcontract and Subcontractor employees working on this subcontract will be subject to the whistleblower rights and remedies in the pilot program on Contractor employee whistleblower protections established at 41 U.S.C. 4712 by section 828 of the National Defense Authorization Act for Fiscal Year 2013 (Pub. L.112-239) and FAR 3.908.

The Subcontractor shall inform its employees in writing, in the predominant language of the workforce, of employee whistleblower rights and protections under 41 U.S.C. 4712, as described in section 3.908 of the Federal Acquisition Regulation.

If lower tier subcontracting is authorized in this subcontract, the Subcontractor shall insert the substance of this clause in all subcontracts over the simplified acquisition threshold.

#### Reporting on Subcontractor Data Pursuant to the Requirements of the Federal Funding Accountability and Transparency Act

- a) Public Availability of Information.



Pursuant to the requirements of FAR 52.204-10, Chemonics is required to report information regarding its award of subcontracts and sub-task orders under indefinite delivery/indefinite quantity subcontracts to the Federal Funding Accountability and Transparency Act Subaward Reporting System (FSRS). This information will be made publicly available at <http://www.USASpending.gov>.

(b) Subcontractor's Responsibility to Report Identifying Data.

**Within 7 days of an award of a subcontract or sub-task order with a value of \$30,000 or greater unless exempted, the Subcontractor shall report its identifying data required by FAR 52.204-10 (including executive compensation, if applicable) in the required questionnaire and certification found in Section I.6.** If the Subcontractor maintains a record in the System for Award Management ([www.SAM.gov](http://www.SAM.gov)), the Subcontractor shall keep current such registration, including reporting of executive compensation data, as applicable. If reporting of executive compensation is applicable and the Subcontractor does not maintain a record in the System for Award Management, Subcontractor shall complete the "FSRS Reporting Questionnaire and Certification" found in Section I.6 within 7 days of each anniversary of the subcontract award date.

(c) Impracticality of Registration.

If obtaining a UEI number and reporting data is impractical for the Subcontractor, the Subcontractor must notify Chemonics and shall submit to Chemonics within 7 days of subcontract award a memorandum detailing the attempts made by the Subcontractor to obtain registration and a justification of why registration and/or data reporting was impractical. Contractual remedies may apply unless Chemonics concurs with the documented impracticality of registration.

(d) Remedy.

Failure to comply with the reporting requirements in a timely manner as required under this section may constitute a material breach of the Subcontract and cause for withholding payment to the Subcontractor until the required information has been supplied to Chemonics or the Subcontractor demonstrates to Chemonics that its System for Award Management record has been updated. In addition to contractual remedies, Chemonics may make the Subcontractor's failure to comply with the reporting requirements a part of the Subcontractor's performance information record.

#### Miscellaneous

(a) This Subcontract embodies the entire agreement and understanding among the parties hereto with respect to the subject matter hereof and supersedes all prior oral or written agreements and understandings between or among the parties relating to the subject matter hereof. No statement, representation, warranty, covenant, or agreement of any kind not expressly set forth in this Subcontract shall affect, or be used to interpret, change, or restrict the express terms and provisions of this Subcontract. Each of the parties hereto agrees to cooperate with the other parties hereto in effectuating this Subcontract and to execute and deliver such further documents or instruments and to take such further actions as shall be reasonably requested in connection therewith.

(b) All statements, representations, warranties, covenants, and agreements in this Subcontract shall be binding on the parties hereto and shall inure to the benefit of the respective successors and permitted assigns of each Party hereto. Nothing in this Subcontract shall be construed to create any rights or obligations except among the parties hereto, and no person or entity shall be regarded as a third-party beneficiary of this Subcontract.

- (c) In the event that any court of competent jurisdiction shall determine that any provision, or any portion thereof, contained in this Subcontract shall be unenforceable or invalid in any respect, then such provision shall be deemed limited to the extent that such court deems it valid or enforceable, and as so limited shall remain in full force and effect. In the event that such court shall deem any such provision partially or wholly unenforceable, the remaining provisions of this Subcontract shall nevertheless remain in full force and effect.
- (d) The headings and captions contained in this Subcontract are for convenience only and shall not affect the meaning or interpretation of this Subcontract or of any of its terms or provisions.
- (e) Unless otherwise specifically agreed in writing to the contrary: (i) the failure of any party at any time to require performance by the other of any provision of this Subcontract shall not affect such party's right thereafter to enforce the same; (ii) no waiver by any party of any default by any other shall be valid unless in writing and acknowledged by an authorized representative of the non-defaulting party, and no such waiver shall be taken or held to be a waiver by such party of any other preceding or subsequent default; and (iii) no extension of time granted by any party for the performance of any obligation or act by any other party shall be deemed to be an extension of time for the performance of any other obligation or act hereunder.
- (f) Each party has been represented by its own counsel in connection with the negotiation and preparation of this Subcontract and, consequently, each party hereby waives the application of any rule of law that would otherwise be applicable in connection with the interpretation of this Subcontract, including but not limited to any rule of law to the effect that any provision of this Subcontract shall be interpreted or construed against the party whose counsel drafted that provision.
- (g) This Agreement may be executed in any number of counterparts, and by different parties hereto on separate counterparts, each of which shall be deemed an original, but all of which together shall constitute one and the same instrument.

### Insurance Requirements

Prior to starting work, the Subcontractor at its own expense, shall procure and maintain in force, on all its operations, insurance in accordance with the clause listed below.

The policies of insurance shall be in such form and shall be issued by such company or companies as may be satisfactory to Chemonics. Upon request from Chemonics, the Subcontractor shall furnish Chemonics with certificates of insurance from the insuring companies which shall specify the effective dates of the policies, the limits of liabilities there under, and contain a provision that the said insurance will not be canceled except upon thirty (30) days' notice in writing to Chemonics. The Subcontractor shall not cancel any policies of insurance required hereunder either before or after completion of the work without written consent of Chemonics.

(a) FAR 52.228-3 WORKER'S COMPENSATION INSURANCE (DEFENSE BASE ACT INSURANCE) (JUL 2014)

The Subcontractor shall (a) provide, before commencing performance under this subcontract, such workers' compensation or security as the Defense Base Act (DBA) (42 U.S.C. 1651, et seq.) requires and (b) continue

to maintain it until performance is completed. The Subcontractor shall insert, in all lower-tier subcontracts authorized by Chemonics under this subcontract to which the Defense Base Act applies, a clause similar to this clause imposing upon those lower-tier subcontractors this requirement to comply with the Defense Base Act.

(b) AIDAR 752.228-3 WORKERS' COMPENSATION (DEFENSE BASE ACT) [Updated by AAPD 05-05 — 02/12/04]

As prescribed in AIDAR 728.308, the following supplemental coverage is to be added to the clause specified in FAR 52.228-3.

(1) The Subcontractor agrees to procure DBA insurance pursuant to the terms of the contract between USAID and USAID's DBA insurance carrier unless the Subcontractor has a DBA self-insurance program approved by the U.S. Department of Labor or has an approved retrospective rating agreement for DBA.

(2) If USAID or Subcontractor has secured a waiver of DBA coverage (See AIDAR 728.305-70(a)) for Subcontractor's employees who are not citizens or residents of, or hired in the United States, the Subcontractor agrees to provide such employees with worker's compensation benefits as required by the laws of the country in which the employees are working, or by the laws of the employee's native country, whichever offers greater benefits.

(3) The Subcontractor further agrees to insert in all lower-tier subcontracts hereunder to which the DBA is applicable a clause similar to this clause, including the sentence, imposing on all lower-tier subcontractors authorized by Chemonics a like requirement to provide overseas workmen's compensation insurance coverage and obtain DBA coverage under the USAID requirements contract.

(4) USAID's DBA insurance carrier.

Pursuant to the clause of this Subcontract entitled "Worker's Compensation Insurance (Defense Base Act)" (AIDAR 752.228 03), the Subcontractor shall obtain DBA coverage from USAID's current insurance carrier for such insurance. This insurance carrier as of the effective date of this Subcontract is Starr Indemnity and Liability Company. The agent and program administrator is Marsh MMA. Point of contact is: USAID@marshmma.com. Coverage should be request in accordance with USAID Contract No. 7200AA19D00023/72016922F00001 with Starr/Marsh MMA. The costs of the DBA insurance are allowable and reimbursable as a direct cost to this subcontract.

(c) AIDAR 752.228-70 Medical Evacuation Services (MEDEVAC) Services (JULY 2007) [Updated by AAPD 06-01].

(1) The Subcontractor shall provide MEDEVAC service coverage to all U.S. citizen, U.S. resident alien, and Third Country National employees and their authorized dependents (hereinafter "individual") while overseas under a USAID-financed direct contract. Chemonics will reimburse reasonable, allowable, and allocable costs for MEDEVAC service coverage incurred under this subcontract. The USAID Contracting Officer through Chemonics will determine the reasonableness, allowability, and allocability of the costs based on the applicable cost principles and in accordance with cost accounting standards.

(2) Exceptions:

- (i) The Subcontractor is not required to provide MEDEVAC insurance to eligible employees and their dependents with a health program that includes sufficient MEDEVAC coverage as approved by Chemonics.
- (ii) The USAID Mission Director through Chemonics, may make a written determination to waive the requirement for such coverage. The determination must be based on findings that the quality of local medical services or other circumstances obviate the need for such coverage for eligible employees and their dependents located at post.
- (3) If authorized to issue lower-tier subcontracts, the Subcontractor shall insert a clause similar to this clause in all lower-tier subcontracts that require performance by subcontractor employees overseas.

Section YY. Security

(a) Operating Conditions – Assumption of the Risk

Performance of this Subcontract may involve work under dangerous and austere conditions that include, without limitation, social and political unrest, armed conflict, criminal and terrorist activity, unsanitary conditions and limited availability of health care. The Subcontractor warrants that it has assessed and evaluated the location of performance and nature of the work including, without limitation, local laws, regulations, operational and security conditions and assumes all risks of performance including injury to Subcontractor personnel and loss of damage to Subcontractor property, except as expressly provided herein.

(b) **Access to Chemonics' Facilities – Security Requirements**

Subcontractor's access to property under Chemonics' control is subject to compliance with Chemonics' security requirements. The Subcontractor agrees to provide all necessary information required for employees to be cleared for access to Chemonics' facilities. When present on Chemonics' property, or when Chemonics is providing transportation, the Subcontractor agrees that its employees will comply with Chemonics' security-related procedures and directions. **Failure to adhere to security procedures may lead to an immediate suspension of work, corrective action, or termination of the subcontract.**

(c) **Security Coordination, Reports of Security Threats and Incidents**

The Subcontractor agrees to reasonably cooperate and coordinate with Chemonics to ensure the safety and security of personnel, property and project assets. Such coordination shall include providing information concerning Subcontractor's security platform for facilities that may be visited by Chemonics personnel, USAID, or other participants in the project.

The Subcontractor shall report, as soon as possible (in any case no later than 4 hours), any information concerning threats of actions that could result in injury persons, damage to property, or disruption to activities relating to the Subcontract ("Security Threats"). Security Threats must be reported to Chemonics Chief of Party or his/her designee.

The Subcontractor shall promptly report as "Security Incidents" any assault, damage, theft, sabotage, breach of secured facilities, and any other hostile or unlawful acts designed to cause harm to personnel, property, or activities relating to the Subcontract. Such reports must include, at a minimum (a) date, time and place of the location, (b) description of the events, (c) injuries to personnel or damage/loss of property, (d) witnesses, (e) current security assessment, and (f) other relevant information. Security Incident Reports must be sent to Chief of Party or his/her designee.

Section Z. Federal Acquisition Regulation (FAR) And Agency For International Development Acquisition Regulation (AIDAR) Flow-down Provisions For Subcontracts And Task Orders Under USAID Prime Contracts

**Z.1 INCORPORATION OF FAR AND AIDAR CLAUSES**

The FAR and AIDAR clauses referenced below are incorporated herein by reference, with the same force and effect as if they were given in full text, and are applicable, including any notes following the clause citation, to this Subcontract. If the date or substance of any of the clauses listed below is different from the date or substance of the clause actually incorporated in the Prime Contract referenced by number herein, the date or substance of the clause incorporated by said Prime Contract shall apply instead. The Contracts Disputes Act shall have no application to this Subcontract. Any reference to a "Disputes" clause shall mean the "Disputes" clause of this Subcontract.

**Z.2 GOVERNMENT SUBCONTRACT**

- (a) This Subcontract is entered into by the parties in support of a U.S. Government contract.
- (b) As used in the AIDAR clauses referenced below and otherwise in this Subcontract:
  - 1. "Commercial Item" means a commercial item as defined in FAR 2.101.
  - 2. "Contract" means this Subcontract.
  - 3. "Contracting Officer" shall mean the U.S. Government Contracting Officer for Chemonics' government prime contract under which this Subcontract is entered.
  - 4. "Contractor" and "Offeror" means the Subcontractor, which is the party identified on the face of the Subcontract with whom Chemonics is contracting, acting as the immediate subcontractor to Chemonics.
  - 5. "Prime Contract" means the contract between Chemonics and the U.S. Government.
  - 6. "Subcontract" means any contract placed by subcontractor or lower-tier subcontractors under this Contract.

**Z.3 NOTES**

The following notes apply to the clauses incorporated by reference below only when specified in the parenthetical phrase following the clause title and date.

- 1. Substitute "Chemonics" for "Government" or "United States" throughout this clause.

2. Substitute "Chemonics Procurement Representative" for "Contracting Officer", "Administrative Contracting Officer", and "ACO" throughout this clause.
3. Insert "and Chemonics" after "Government" throughout this clause.
4. Insert "or Chemonics" after "Government" throughout this clause.
5. Communication/notification required under this clause from/to Subcontractor to/from the USAID Contracting Officer shall be through Chemonics.
6. Insert "and Chemonics" after "Contracting Officer", throughout the clause.
7. Insert "or Chemonics Procurement Representative" after "Contracting Officer", throughout the clause.
8. If the Subcontractor is a non-U.S. firm or organization, this clause applies to this Subcontract only if Work under the Subcontract will be performed in the United States or Subcontractor is recruiting employees in the United States to Work on the Contract.

#### **Z.4 MODIFICATIONS REQUIRED BY PRIME CONTRACT**

The Subcontractor agrees that upon the request of Chemonics it will negotiate in good faith with Chemonics relative to modifications to this Subcontract to incorporate additional provisions herein or to change provisions hereof, as Chemonics may reasonably deem necessary in order to comply with the provisions of the applicable Prime Contract or with the provisions of modifications to such Prime Contract. If any such modifications to this Subcontract causes an increase or decrease in the cost of, or the time required for, performance of any part of the Work under this Contract, an equitable adjustment may be made pursuant to the "Changes" clause of this Subcontract.

#### **Z.5 PROVISIONS INCORPORATED BY REFERENCE**

This Subcontract includes the appropriate flow-down clauses as required by the Federal Acquisition Regulation and the USAID Acquisition Regulation.

**The following Federal Acquisition Regulation (FAR) clauses apply to this Subcontract as indicated:**

**\* The version of the clause in effect as of the date of prime contract award, governs.**

<b>Clause Number</b>	<b>Title</b>	<b>Date*</b>	<b>Notes and Applicability</b>
<u>52.202-1</u>	DEFINITIONS	JUNE 2020	All subcontracts regardless of value
<u>52.203-3</u>	GRATUITIES	APR 1984	All subcontracts regardless of value (Note 4 applies)
<u>52.203-5</u>	COVENANT AGAINST CONTINGENT FEES	MAY 2014	All subcontracts regardless of value (Note 1 applies)
<u>52.203-6</u>	RESTRICTIONS ON SUBCONTRACTOR SALES TO THE GOVERNMENT	JUN 2020	Cost reimbursement subcontracts and cost reimbursement task orders (Note 4 applies)
<u>52.203-7</u>	ANTI-KICKBACK PROCEDURES	JUN 2020	All subcontracts regardless of value (Note 1 applies)
<u>52.203-8</u>	CANCELLATION, RECISSION, AND RECOVERY OF FUNDS FOR ILLEGAL OR IMPROPER ACTIVITY	MAY 2014	All subcontracts equal to or greater than the simplified acquisition threshold (Note 1 applies)
<u>52.203-10</u>	PRICE OR FEE ADJUSTMENT FOR ILLEGAL OR IMPROPER ACTIVITY	MAY 2014	All subcontracts equal to or greater than the simplified acquisition threshold (Note 1 applies)

Clause Number	Title	Date*	Notes and Applicability
<u>52.203-11</u>	CERTIFICATION AND DISCLOSURE REGARDING PAYMENTS TO INFLUENCE CERTAIN FEDERAL TRANSACTIONS	SEP 2007	All subcontracts equal to or greater than \$150,000 (Note 2 applies)
<u>52.203-12</u>	LIMITATIONS ON PAYMENTS TO INFLUENCE CERTAIN FEDERAL TRANSACTIONS	JUN 2020	All subcontracts equal to or greater than \$150,000 (Note 2 applies)
<u>52.203-13</u>	CONTRACTOR CODE OF BUSINESS ETHICS AND CONDUCT	NOV 2011	All subcontracts that have a value in excess of \$5.5 million and a performance period of more than 120 days. Disclosures made under this clause shall be directed to the agency Office of the Inspector General, with a copy to the Contracting officer.
<u>52.203-14</u>	DISPLAY OF HOTLINE POSTER(S)	NOV 2021	All subcontracts that have a value in excess of \$5.5 million except those performed entirely outside of the U.S. (Note 8 applies)
<u>52.203-17</u>	CONTRACTOR EMPLOYEE WHISTLEBLOWER RIGHTS AND REQUIREMENTS TO INFORM EMPLOYEES OF WHISTLEBLOWER RIGHTS	JUN 2020	All Subcontracts equal to or greater than the simplified acquisition threshold
<u>52.204-06</u>	UNIQUE ENTITY IDENTIFIER	OCT 2016	All Subcontracts equal to or greater than \$30,000
<u>52.204-10</u>	REPORTING EXECUTIVE COMPENSATION AND FIRST TIER SUBCONTRACT AWARDS (Subparagraph (d)(2) does not apply.)	JUN 2020	If the Subcontractor meets the thresholds specified in paragraphs (d)(3) and (g)(2) of the clause, the Subcontractor shall report required executive compensation by posting to the Government's Central Contractor Registration (CCR) database. All information posted will be available to the general public.
<u>52.204-23</u>	PROHIBITION ON CONTRACTING FOR HARDWARE, SOFTWARE AND SERVICES DEVELOPED BY KASPERSKY LAB AND OTHER COVERED ENTITIES	NOV 2021	Applies to all subcontracts, regardless of value or type. "Contractor" and "Contractor Employee" refer to "Subcontractor" and "Subcontractor Employee."
<u>52.204-25</u>	PROHIBITION ON CONTRACTING FOR CERTAIN TELECOMMUNICATIONS AND VIDEO SURVEILLANCE SERVICES OR EQUIPMENT	NOV 2021	All subcontracts regardless of value (Note 1 applies)
52.209-2	PROHIBITION ON CONTRACTING WITH INVERTED DOMESTIC CORPORATIONS - REPRESENTATION	NOV 2015	All subcontracts regardless of value (Note 1 applies)
<u>52.209-6</u>	PROTECTING THE GOVERNMENT'S INTEREST WHEN SUBCONTRACTING WITH CONTRACTORS DEBARRED, SUSPENDED, OR PROPOSED FOR DEBARMENT	NOV 2012	All Subcontracts > \$35,000. (Note 2 applies)
<u>52.209-10</u>	PROHIBITION ON CONTRACTING WITH INVERTED DOMESTIC CORPORATIONS	NOV 2015	All subcontracts regardless of value (Note 1 applies)
<u>52.215-2</u>	AUDITS AND RECORDS - NEGOTIATION	JUN 2020	All Subcontracts except those below the simplified acquisition threshold. (Note 3 applies. Alternate II applies if the Subcontractor is an educational or non-profit organization.)
<u>52.215-10</u>	PRICE REDUCTION FOR DEFECTIVE CERTIFIED COST OR PRICING DATA  Rights and obligations under this clause shall survive completion of the Work and final payment under this Subcontract.	AUG 2011	Applies if submission of certified cost or pricing data was required with Subcontractor's proposal. (Notes 2 and 4 apply except the first time "Contracting Officer" appears in paragraph (c)(1). "Government" means "Chemonics" in paragraph (d)(1).)

Clause Number	Title	Date*	Notes and Applicability
<u>52.215-11</u>	PRICE REDUCTION FOR DEFECTIVE CERTIFIED COST OR PRICING DATA -- MODIFICATIONS Rights and obligations under this clause shall survive completion of the Work and final payment under this Subcontract.	JUN 2020	Applies if submission of certified cost or pricing data is required for modifications. (Notes 1, 2 and 4 apply.)
<u>52.215-12</u>	SUBCONTRACTOR CERTIFIED COST OR PRICING DATA	NOV 2021	Applies if Subcontract > \$750,000 and is not otherwise exempt under FAR 15.403.
<u>52.215-13</u>	SUBCONTRACTOR CERTIFIED COST OR PRICING DATA—MODIFICATIONS	JUN 2020	Applies if Subcontract > \$750,000 and is not otherwise exempt under FAR 15.403.
<u>52.215-14</u>	INTEGRITY OF UNIT PRICES	NOV 2021	Applies if Subcontract is above the simplified acquisition threshold. Delete paragraph (b) of the clause.
<u>52.215-15</u>	PENSION ADJUSTMENTS AND ASSET REVERSIONS	OCT 2010	Applies if Subcontract meets the applicability requirements of FAR 15.408(g). (Note 5 applies.)
<u>52.215-16</u>	FACILITIES CAPITAL COST OF MONEY	JUN 2003	Applies if Subcontract is subject to the Cost Principles at FAR Subpart 31.2 and Subcontractor proposed facilities capital cost of money in its proposal.
<u>52.215-17</u>	WAIVER OF FACILITIES CAPITAL COST OF MONEY	OCT 1997	Applies if Subcontract is subject to the Cost Principles at FAR Subpart 31.2 and Subcontractor did not propose facilities capital cost of money in its proposal.
<u>52.215-18</u>	REVERSION OR ADJUSTMENT OF PLANS FOR POST-RETIREMENT BENEFITS (PRB) OTHER THAN PENSIONS	JUL 2005	Applicable if this Subcontract meets the applicability requirements of FAR 15.408(j). (Note 5 applies.)
<u>52.215-19</u>	NOTIFICATION OF OWNERSHIP CHANGES	OCT 1997	Applies if this Subcontract meets the applicability requirements of FAR 15.408(k). (Note 5 applies.)
<u>52.215-20</u>	REQUIREMENTS FOR CERTIFIED COST OR PRICING DATA OR INFORMATION OTHER THAN CERTIFIED COST OR PRICING DATA.	NOV 2021	(Note 2 applies.)
<u>52.215-21</u>	REQUIREMENTS FOR CERTIFIED COST OR PRICING DATA OR INFORMATION OTHER THAN CERTIFIED COST OR PRICING DATA - MODIFICATIONS	NOV 2021	(Note 2 applies)
<u>52.215-23</u>	LIMITATION ON PASS-THROUGH CHARGES	JUN 2020	Applies for cost-reimbursement subcontracts which exceed the simplified acquisition threshold. (Notes 1, 2 and 4 apply.)
<u>52.216-7</u>	ALLOWABLE COST AND PAYMENT Alt II applies to educational institutions. Alt IV applies to non-profit organizations.	AUG 2018	Applies to Cost Reimbursement Subcontracts, and to the materials portion of Time & Materials (T&M) Subcontracts, and Sub-task Orders. (Note 1 applies except in paragraphs (a)(3) and (b)(1)(ii)(F) where note 3 applies. Note 2 applies except in paragraph (g) where note 7 applies. The blank in paragraph (a)(3) is completed with "the 30th" unless otherwise specified in this Subcontract. Paragraphs (a)(2), (b)(4), and (d)(4) are deleted. In paragraph (h) "six years" is changed to "5 years." The references to government entities in paragraph (d) are unchanged.)
<u>52.216-8</u>	FIXED FEE	JUN 2011	Applies only if this Subcontract includes a fixed fee. Delete the last two sentences of the clause.



Clause Number	Title	Date*	Notes and Applicability
			Does not apply if this is a T&M Subcontract or Task Order. (Notes 1 and 2 apply.)
<u>52.216-10</u>	INCENTIVE FEE	JUN 2011	Applies only if this Subcontract includes an incentive fee. Does not apply if this is a T&M Subcontract or Task Order. (Notes 1 and 2 apply, except in paragraphs (e)(4)(v) and (e)(4)(vi) where "Government" is unchanged. Subparagraph (e)(4)(iv) and the last two sentences of paragraph (c)(2) are deleted. The amounts in paragraph (e) are set forth in the Subcontract.)
<u>52.216-11</u>	COST CONTRACT - NO FEE	APR 1984	Applies only to Cost Reimbursement-No Fee Subcontracts. Does not apply if this is a T&M Subcontract or Task Order. (Notes 1 and 2 apply.)
<u>52.216-18</u>	ORDERING	AUG 2020	Applies to Indefinite Quantity Subcontracts (IQS) Or Indefinite Delivery Indefinite Quantity (IDIQ) Subcontracts only.
<u>52.216-19</u>	ORDER LIMITATIONS	OCT 1995	Applies to Indefinite Quantity Subcontracts (IQS) Or Indefinite Delivery Indefinite Quantity (IDIQ) Subcontracts only.
<u>52.216-22</u>	INDEFINITE QUANTITY	OCT 1995	Applies to Indefinite Quantity Subcontracts (IQS) Or Indefinite Delivery Indefinite Quantity (IDIQ) Subcontracts only.
<u>52.217-8</u>	OPTION TO EXTEND SERVICES	NOV 1999	Insert "30 days" as <i>the period of time within which Chemonics may exercise the option.</i> (Notes 1 and 2 apply.)
<u>52.217-9</u>	OPTION TO EXTEND THE TERM OF THE CONTRACT	MAR 2000	Insert "30 days" and "60 days" as the periods of time set forth in the clause. Delete paragraph (c) of the clause. (Notes 1 and 2 apply.)
<u>52.219-8</u>	UTILIZATION OF SMALL BUSINESS CONCERNS	OCT 2018	Applies to all Subcontracts that are expected to exceed the simplified acquisition threshold except when the Subcontract will be performed entirely outside of the U.S. (Note 8 applies.)
<u>52.219-9</u>	SMALL BUSINESS SUBCONTRACTING PLAN  (If a subcontracting plan was required by the RFP, the plan is incorporated herein by reference.)	NOV 2021	Applies if this Subcontract > \$750,000 and if the Subcontract offers lower-tier subcontracting opportunities. The clause <i>does not</i> apply at any value if the Subcontractor is U.S. small business concern. Note 2 is applicable to paragraph (c) only. (Note 8 applies.)
<u>52.222-2</u>	PAYMENT FOR OVERTIME PREMIUMS	JUL 1990	Applicable to Cost Reimbursement Subcontracts which are expected to exceed the simplified acquisition threshold only. Refers to overtime premiums for work performed in the U.S. subject to U.S. Department of Labor laws and regulations. Insert Zero in the blank. (Notes 2 and 3 apply.)
<u>52.222-3</u>	CONVICT LABOR	JUN 2003	Applies to all Subcontracts >\$3,000 involving some or all performance in the U.S.
<u>52.222-21</u>	PROHIBITION OF SEGREGATED FACILITIES	APR 2015	(Note 8 applies.) Does not apply to work performed outside the United States by Subcontractor employees who were not recruited within the United States.
<u>52.222-22</u>	PREVIOUS CONTRACTS AND COMPLIANCE	FEB	Applies if clause 52.222-26 applies.

Clause Number	Title	Date*	Notes and Applicability
	REPORT	1999	
<a href="#">52.222-26</a>	EQUAL OPPORTUNITY	SEP 2016	Does not apply to work performed outside the United States by Subcontractor employees who were not recruited within the United States.
<a href="#">52.222-29</a>	NOTIFICATION OF VISA DENIAL	APR 2015	Applies to all Subcontracts regardless of type or value.
<a href="#">52.222-35</a>	EQUAL OPPORTUNITY FOR VETERANS	JUN 2020	Applies if this Subcontract is for \$150,000 or more. Does not apply to Subcontracts where the work is performed entirely outside the U.S. by employees recruited outside the United States.
<a href="#">52.222-36</a>	EQUAL OPPORTUNITY FOR WORKERS WITH DISABILITIES	JUN 2020	Applies if this Subcontract exceeds \$15,000. Does not apply to Subcontracts where the work is performed entirely outside the U.S., Puerto Rico, the Northern Mariana Islands, American Samoa, Guam, the U.S. Virgin Islands, and Wake Island. (Note 8 applies.)
<a href="#">52.222-37</a>	EMPLOYMENT REPORTS ON VETERANS	JUN 2020	Applies if this Subcontract contains the FAR clause of 52.222-35, Equal Opportunity for Veterans.
<a href="#">52.222-40</a>	NOTIFICATION OF EMPLOYEE RIGHTS UNDER THE NATIONAL LABOR RELATIONS ACT	DEC 2010	Applies to Subcontracts is above the simplified acquisition threshold. <i>Does not</i> apply to Subcontracts performed <i>entirely</i> outside the U.S. For indefinite-quantity contracts, include the clause only if the value of orders in any calendar year of the contract is expected to exceed the simplified acquisition threshold;
<a href="#">52.222-50</a>	COMBATING TRAFFICKING IN PERSONS (Alternate I applies when work is performed outside the U.S. and it is included in the Prime Contract)	NOV 2021	Applies to all Subcontracts, regardless of type, value. (Note 2 applies starting in paragraph c. In paragraph (h) Note 1 applies.)
<a href="#">52.222-54</a>	EMPLOYMENT ELIGIBILITY VERIFICATION	NOV 2021	Applies to Subcontracts which exceed the simplified acquisition threshold <i>except for</i> a) commercial services that are part of the purchase of a Commercial Off-the-Shelf (COTS) item (or an item that would be a COTS item, but for minor modifications), performed by the COTS provider, and are normally provided for that COTS item; b) Subcontracts for work that will be performed outside the United States; or Subcontracts with a period of performance < 120 days.
<a href="#">52.223-6</a>	DRUG-FREE WORKPLACE	MAY 2001	Applies to all Subcontracts regardless of value or type. (Notes 2 and 4 apply)
<a href="#">52.223-18</a>	ENCOURAGING CONTRACTOR POLICIES TO BAN TEXT MESSAGING WHILE DRIVING	JUN 2020	Applies to all subcontracts regardless of value.
<a href="#">52.225-1</a>	BUY AMERICAN ACT -- SUPPLIES	NOV 2021	Applies if the Statement of Work contains other than domestic components. (Note 2 applies.)
<a href="#">52.225-13</a>	RESTRICTIONS ON CERTAIN FOREIGN PURCHASES	FEB 2021	Applies to all Subcontracts regardless of value or type
<a href="#">52.225-14</a>	INCONSISTENCY BETWEEN ENGLISH VERSION AND TRANSLATION OF CONTRACT	FEB 2000	Applies to all Subcontracts regardless of value or type
<a href="#">52.227-1</a>	AUTHORIZATION AND CONSENT	JUN 2020	Applies if the Subcontract is above the simplified acquisition threshold. (Notes 4 and 7 apply.), not applicable when both the performance and delivery are outside the United States

Clause Number	Title	Date*	Notes and Applicability
<u>52.227-2</u>	NOTICE AND ASSISTANCE REGARDING PATENT AND COPYRIGHT INFRINGEMENT	JUN 2020	Applies only if FAR clause 52.221-1 is included in the subcontract
<u>52.227-9</u>	REFUND OF ROYALTIES	APR 1984	Applies if this Subcontract includes royalties
<u>52.227-14</u>	RIGHTS IN DATA - GENERAL	MAY 2014	Applies to all subcontracts regardless of type or value. Delete paragraph (d) which is replaced by AIDAR 752.227-14.
<u>52.228-3</u>	WORKER'S COMPENSATION INSURANCE (DEFENSE BASE ACT)	JUL 2014	Applies to all Subcontracts, regardless of type or value. See also AIDAR 752.228-3.
<u>52.228-4</u>	WORKER'S COMPENSATION AND WAR-HAZARD INSURANCE OVERSEAS	APR 1984	Applies to all Subcontracts, regardless of type or value, only if the Prime Contracts includes this clause.
<u>52.228-7</u>	INSURANCE—LIABILITY TO THIRD PERSONS	MAR 1996	Applicable to Cost Reimbursement Subcontracts and Task Orders of any value. (Notes 4 and 7 apply)
<u>52.228-9</u>	CARGO INSURANCE	MAY 1999	Applicable to Subcontracts of any value if the Subcontractor is authorized to provide transportation-related services. Chemonics will provide values to complete blanks in this clause upon authorizing transportation services. (see also AIDAR 752.228-9)
<u>52.229-6</u>	TAXES – FOREIGN FIXED PRICE CONTRACTS	FEB 2013	Applies to Fixed Price Subcontracts of any value.
<u>52.229-8</u>	TAXES—FOREIGN COST-REIMBURSEMENT CONTRACTS	MAR 1990	Applicable to Cost Reimbursement and T&M Subcontracts and Task Orders, regardless of value. Insert name of host country government in first blank in the clause. Insert name of host country in second blank in the clause.
<u>52.230-2</u>	COST ACCOUNTING STANDARDS	JUN 2020	Applies only when referenced in this Subcontract that full CAS coverage applies. "United States" means "United States or Chemonics." Delete paragraph (b) of the clause.
<u>52.230-3</u>	DISCLOSURE AND CONSISTENCY OF COST ACCOUNTING PRACTICES	JUN 2020	Applies only when referenced in this Subcontract that modified CAS coverage applies. "United States" means "United States or Chemonics." Delete paragraph (b) of the clause.
<u>52.230-4</u>	DISCLOSURE AND CONSISTENCY OF COST ACCOUNTING PRACTICES FOR CONTRACTS AWARDED TO FOREIGN CONCERNS	JUN 2020	Applies only when referenced in this Subcontract, modified CAS coverage applies. Note 3 applies in the second and third sentences.
<u>52.230-5</u>	COST ACCOUNTING STANDARDS -- EDUCATIONAL INSTITUTIONS	JUN 2020	"United States" means "United States or Chemonics." Delete paragraph (b) of the Clause. Applies only when referenced in this Subcontract that this CAS clause applies.
<u>52.230-6</u>	ADMINISTRATION OF COST ACCOUNTING STANDARDS	JUN 2010	Applies if FAR 52.230-2, FAR 52.230-3, FAR 52.230-4 or FAR 52.230-5 applies.
<u>52.232-20</u>	LIMITATION OF COST	APR 1984	Applies if this Subcontract is a fully funded Cost Reimbursement or T&M Subcontract or Task Order. (Notes 1 and 2 apply.)
<u>52.232-22</u>	LIMITATION OF FUNDS	APR 1984	Applies if this Subcontract is an incrementally funded Cost Reimbursement or T&M Subcontract or Task Order. (Notes 1 and 2 apply.)
<u>52.232-40</u>	PROVIDING ACCELERATED PAYMENTS TO SMALL BUSINESS SUBCONTRACTORS	NOV 2021	Applies if the Subcontractor is a U.S. small business and Chemonics receives accelerated

Clause Number	Title	Date*	Notes and Applicability
			payments under the prime contract. (Note 1 applies.)
<u>52.233-3</u>	<p>PROTEST AFTER AWARD</p> <p>Alternate I (JUN 1985) applies if this is a cost-reimbursement contract). In the event that Chemonics' client has directed Chemonics to stop performance of the Work under the Prime Contract under which this Subcontract is issued pursuant to FAR 33.1, Chemonics may, by written order to the Subcontractor, direct the Subcontractor to stop performance of the Work called for by this Subcontract.</p>	AUG 1996	"30 days" means "20 days" in paragraph (b)(2). Note 1 applies except the first time "Government" appears in paragraph (f). In paragraph (f) add after "33.104(h) (1)" the following: "and recovers those costs from Chemonics".
<u>52.237-8</u>	RESTRICTION ON SEVERANCE PAYMENTS TO FOREIGN NATIONALS	AUG 2003	Applies to Subcontracts--regardless of type and value--that include provision of host country national personnel.
<u>52.237-9</u>	<p>INSTRUCTIONS: INCLUDE THIS ONLY IF IT APPEARS IN THE PRIME CONTRACT.</p> <p>WAIVER OF LIMITATION ON SEVERANCE PAYMENTS TO FOREIGN NATIONALS</p>	MAY 2014	Applies to Subcontracts—regardless of type and value--that include provision of host country national personnel ONLY if the Prime Contracts includes this clause.
<u>52.242-1</u>	NOTICE OF INTENT TO DISALLOW COSTS	APR 1984	Applies to Cost Reimbursement and T&M Subcontracts and Task Orders of any value.
<u>52.242-3</u>	PENALTIES FOR UNALLOWABLE COSTS	SEP 2021	Applies to all subcontracts > \$800,000, regardless of subcontract type.
<u>52.242-4</u>	CERTIFICATION OF FINAL INDIRECT COSTS	JAN 1997	Applies to Cost Reimbursement and T&M Subcontracts and Task Orders that provide for reimbursement of Subcontractor indirect cost rates, regardless of subcontract value.
<u>52.242-13</u>	BANKRUPTCY	JUL 1995	Notes 1 and 2 apply.
<u>52.242-15</u>	<p>STOP-WORK ORDER</p> <p>Alternate I (APR 1984) applies if this is a cost-reimbursement Subcontract.</p>	AUG 1989	Notes 1 and 2 apply.
<u>52.243-1</u>	CHANGES-FIXED PRICE (Alt III)	AUG 1987	Applies to Fixed Price Subcontracts of any value.
<u>52.243-2</u>	CHANGES - COST REIMBURSEMENT	AUG 1987	Notes 1 and 2 apply. Applies if this is a Cost Reimbursement Subcontract or Task Order.
<u>52.243-3</u>	CHANGES - TIME-AND-MATERIALS OR LABOR-HOUR	SEP 2000	Notes 1 and 2 apply. Applies if this is a T&M Subcontract or Task Order.
<u>52.244-6</u>	SUBCONTRACTS FOR COMMERCIAL ITEMS	JAN 2022	Applies to Subcontracts for commercial items only.

Clause Number	Title	Date*	Notes and Applicability
<u>52.245-1</u>	GOVERNMENT PROPERTY (APR 2012) (ALT I)	SEP 2021	"Contracting Officer" means "Chemionics" except in the definition of Property Administrator and in paragraphs (h)(1)(iii) where it is unchanged, and in paragraphs (c) and (h)(4) where it includes Chemionics. "Government" is unchanged in the phrases "Government property" and "Government furnished property" and where elsewhere used except in paragraph (d)(1) where it means "Chemionics" and except in paragraphs (d)(2) and (g) where the term includes Chemionics.
<u>52.246-3</u>	INSPECTION OF SUPPLIES - COST REIMBURSEMENT  Applies to Cost Reimbursement Subcontracts and Task Orders.	MAY 2001	Note 1 applies, except in paragraphs (b), (c), and (d) where Note 3 applies, and in paragraph (k) where the term is unchanged. In paragraph (e), change "60 days" to "120 days", and in paragraph (f) change "6 months" to "12 months"
<u>52.246-4</u>	INSPECTION OF SERVICES – FIXED PRICE	AUG 1996	Applies to Fixed Priced Subcontracts of any value.
<u>52.246-5</u>	INSPECTION OF SERVICES—COST REIMBURSEMENT	APR 1984	Applies to Cost Reimbursement Subcontracts of any value. (Note 3 applies in paragraphs (b) and (c). Note 1 applies in paragraphs (d) and (e).)
<u>52.246-6</u>	INSPECTION—TIME-AND-MATERIAL AND LABOR-HOUR	MAY 2001	Applies to T&M Subcontracts and Task Orders of any value. In paragraphs (b), (c), (d), Note 3 applies; in paragraphs (e), (f), (g), (h), Note 1 applies.)
<u>52.246-25</u>	LIMITATION OF LIABILITY - SERVICES	FEB 1997	Applies to Subcontracts at or below the simplified acquisition threshold or more.
<u>52.247-63</u>	PREFERENCE FOR U.S.-FLAG AIR CARRIERS	JUN 2003	Applies to all Subcontracts that include international air travel.
<u>52.247-64</u>	PREFERENCE FOR PRIVATELY OWNED U.S. FLAG COMMERCIAL VESSELS	NOV 2021	Applies for Subcontracts that include provision of freight services.
<u>52.247-67</u>	SUBMISSION OF TRANSPORTATION DOCUMENTS FOR AUDIT	FEB 2006	Applies to Subcontracts that include provision of freight services.
<u>52.249-1</u>	TERMINATION FOR CONVENIENCE OF THE GOVERNMENT (FIXED-PRICE) (SHORT FORM)	APR 1984	Applies to all Fixed Price Subcontracts.
<u>52.249-6</u>	TERMINATION (COST-REIMBURSEMENT)  Alternate IV (SEP 1996) applies if this is a time and materials Subcontract.)	MAY 2004	Notes 1 and 2 apply. Substitute "90 days" for "120 days" and "90-day" for "120-day" in paragraph (d). Substitute "180 days" for "1 year" in paragraph (f). In paragraph (j) "right of appeal", "timely appeal" and "on an appeal" shall mean the right to proceed under the "Disputes" clause of this Contract. Settlements and payments under this clause may be subject to the approval of the Contracting Officer.
<u>52.249-8</u>	DEFAULT FIXED PRICE SUPPLY & SERVICE	APR 1984	Applies to all Fixed Price Subcontracts.
<u>52.249-14</u>	EXCUSABLE DELAYS	APR 1984	(Note 2 applies; Note 1 applies to (c). In (a)(2) delete "or contractual".)

**The following Agency for International Development Acquisition Regulations (AIDAR) clauses apply to this Contract:**

Clause Number	Title	Date*	Notes and Applicability
752.202-1	DEFINITIONS (ALT 70 AND ALT 72)	JAN 1990	Applies to all Subcontracts, regardless of value or type. “Contractor” and “Contractor Employee” refer to “Subcontractor” and “Subcontractor Employee”.
752.211-70	LANGUAGE AND MEASUREMENT	JUN 1992	Applies to all Subcontracts, regardless of type or value.
752.225-70	SOURCE AND NATIONALITY REQUIREMENTS	FEB 2012	Applies to all Subcontracts, regardless of type or value. (Notes 4, 5 and 7 apply)
752.227-14	RIGHTS IN DATA – GENERAL	OCT 2007	Applies to all Subcontracts regardless of type or value. This clause replaces paragraph (d) of FAR 52.227-14 Rights in Data—General.
752.228-3	WORKER’S COMPENSATION INSURANCE (DEFENSE BASE ACT)	DEC 1991	The supplemental coverage described in this clause is required in addition to the coverage specified in FAR 52.228-3.
752.228-7	INSURANCE – LIABILITY TO THIRD PERSONS	JULY 1997	The coverage described in this clause is added to the clause specified in FAR 52.228-7 as either paragraph (h) (if FAR 52.228-7 Alternate I is not used) or (i) (if FAR 52.228-7 Alternate I is used): (See FAR 52.228)
752.228-9	CARGO INSURANCE	DEC 1998	The following preface is to be used preceding the text of the clause at FAR 52.228-9: Preface: To the extent that marine insurance is necessary or appropriate under this contract, the Subcontractor shall ensure that U.S. marine insurance companies are offered a fair opportunity to bid for such insurance. This requirement shall be included in all lower-tier subcontracts.
752.228-70	MEDICAL EVACUATION (MEDEVAC) SERVICES	JUL 2007	Applies to all Subcontracts requiring performance outside the U.S.
752.231-71	SALARY SUPPLEMENTS FOR HG EMPLOYEES (THE SUBCONTRACTOR SHALL FLOW DOWN THIS CLAUSE TO LOWER-TIER SUBCONTRACTS, IF LOWER-TIER SUBCONTRACTING IS AUTHORIZED.)	MAR 2015	Applies to all Subcontracts, regardless of value or type, with a possible need for services of a Host Government employee. (Note 5 applies)
752.245-71	TITLE TO AND CARE OF PROPERTY	APR 1984	Applies to Subcontracts where the Subcontractor is authorized by Chemonics to purchase property under the Subcontract for use outside the U.S. (Note 5 applies)
752.247-70	PREFERENCE FOR PRIVATELY OWNED U.S.-FLAG COMMERCIAL VESSELS	OCT 1996	(Note 5 applies)

Clause Number	Title	Date*	Notes and Applicability
752.7001	BIOGRAPHICAL DATA	JUL 1997	Applies to all Cost Reimbursement Subcontracts and Task Orders, and T&M Subcontracts and Task Orders utilizing a multiplier, regardless of value. (Note 3 applies)
752.7002	TRAVEL AND TRANSPORTATION	JAN 1990	Applies to all Cost Reimbursement and T&M Subcontracts and Task Orders performed in whole or in part outside the U.S., regardless of value. (Note 5 applies)
752.7004	EMERGENCY LOCATOR INFORMATION	JUL 1997	Applies to all Subcontracts performed in whole or in part outside the U.S., regardless of value. (Note 5 applies)
752.7005	SUBMISSION REQUIREMENTS FOR DEVELOPMENT EXPERIENCE DOCUMENTS	SEP 2013	Applies to all Subcontracts. (Note 5 applies)
752.7007	PERSONNEL COMPENSATION	JUL 2007	Applies to all Cost Reimbursement Subcontracts and Task Orders and T&M Subcontracts and Task Orders with a multiplier, regardless of value.
752.7008	USE OF GOVERNMENT FACILITIES OR PERSONNEL	APR 1984	Applies to all Subcontracts regardless of value or type. (Note 5 applies)
752.7009	MARKING	JAN 1993	Applies to all Subcontracts. (Note 5 applies)
752.7010	CONVERSION OF U.S. DOLLARS TO LOCAL CURRENCY	APR 1984	Applies to all Subcontracts, regardless of value or type, involving performance outside the U.S. (Note 5 applies)
752.7011	ORIENTATION AND LANGUAGE TRAINING	APR 1984	Applies to Cost Reimbursement Subcontracts and Task Orders, regardless of value, involving performance outside the U.S. (Note 5 applies)
752.7012	PROTECTION OF THE INDIVIDUAL AS A RESEARCH SUBJECT	AUG 1995	Applies to any Subcontract, regardless of value or type, which involves research using human subjects. (Note 5 applies)
752.7013	CONTRACTOR-MISSION RELATIONSHIPS	OCT 1989 DEVIATION (JUN 2020)	Applies to all subcontracts, regardless of value or type. "Contractor" and "Contractor Employee" refer to "Subcontractor" and "Subcontractor Employee."
752.7014	NOTICE OF CHANGES IN TRAVEL REGULATIONS	JAN 1990	Applies to Cost Reimbursement and T&M Subcontracts of any value involving work outside the U.S. (Note 2 applies)
752.7025	APPROVALS	APR 1984	Applies to all Subcontracts. (Note 5 applies)
752.7027	PERSONNEL	DEC 1990	Applies to all Cost Reimbursement and T&M Subcontracts of any value involving work performed in whole or in part overseas. Paragraphs (f) and (g) of this clause are for use only in cost reimbursement and T&M contracts. (Note 5 applies)

Clause Number	Title	Date*	Notes and Applicability
752.7028	DIFFERENTIALS AND ALLOWANCES  APPLIES TO ALL COST REIMBURSEMENT AND T&M SUBCONTRACTS OF ANY VALUE INVOLVING WORK PERFORMED IN WHOLE OR IN PART OVERSEAS.	JUL 1996	This clause does not apply to TCN and CCN employees. TCN and CCN employees are not eligible for differentials and allowances, unless specifically authorized by the cognizant Assistant Administrator or Mission Director. A copy of such authorization shall be retained and made available as part of the contractor's records which are required to be preserved and made available by the "Examination of Records by the Comptroller General" and "Audit" clauses of this contract.) (Note 5 applies)
752.7029	POST PRIVILEGES	JUL 1993	For use in all non-commercial subcontracts involving performance overseas.
752.7031	LEAVE AND HOLIDAYS	OCT 1989	For use in all cost-reimbursement and T&M subcontracts for technical or professional services. (Note 5 applies)
752.7032	INTERNATIONAL TRAVEL APPROVAL AND NOTIFICATION REQUIREMENTS	APR 2014	Applies to all subcontracts requiring international travel. (Note 5 applies)
752.7033	PHYSICAL FITNESS (JULY 1997)	JUL 1997, PARTIALLY REVISED AUG 2014	Applies to all Subcontracts of any type or value involving performance outside the U.S. The requirements of this provision do not apply to employees hired in the Cooperating Country or to authorized dependents who were already in the Cooperating Country when their sponsoring employee was hired. (Note 5 applies)
752.7034	ACKNOWLEDGMENT AND DISCLAIMER	DEC 1991	Applies to Subcontracts of any type or value that include in the Scope of Work publications, videos, or other information/media products. (Note 5 applies)
752.7101	VOLUNTARY POPULATION PLANNING ACTIVITIES	JUN 2008	If a subcontract with family planning activities is contemplated, add "Alternate 1 (6/2008)" to the clause name.

**Z.6 Federal Funding Accountability And Transparency Act (FFATA) Subaward Reporting Questionnaire And Certification For Subcontracts And Sub-Task Orders Under Indefinite Delivery/Indefinite Quantity Subcontracts**

**Subcontractor Name:**

**Subcontract or Sub-Task Order Number:**

**Subcontract or Sub-Task Order Start Date:**

**Subcontract or Sub-Task Order Value:**

The information in this section is required under FAR 52.204-10 "Reporting Executive Compensation and First-Tier Subcontract Awards" to be reported by prime contractors receiving federal contracts through the



Federal Funding Accountability and Transparency Act (FFATA) Subaward Reporting System (FSRS). **As required by the referenced FAR, complete this questionnaire and certification as part of the Subcontract or Sub-Task Order with a value of \$30,000 or more, unless exempted from reporting by a positive response to Section A.**

A. In the previous tax year, was your company's gross income from all sources under \$300,000?

Yes  No

B. If **"No"**, please provide the below information and answer the remaining questions.

(i) **Subcontractor UEI Number:**

(ii) In your business or organization's preceding completed fiscal year, did your business or organization (the legal entity to which the UEI number belongs) receive (1) 80 percent or more of its annual gross revenues in U.S. federal contracts, subcontracts, loans, grants, subgrants, and/or cooperative agreements; and (2) \$25,000,000 or more in annual gross revenues from U.S. federal contracts, subcontracts, loans, grants, subgrants, and/or cooperative agreements?:

Yes  No

(iii) Does the public have access to information about the compensation of the executives in your business or organization (the legal entity to which the UEI number it provided belongs) through periodic reports filed under section 13(a) or 15(d) of the Securities Exchange Act of 1934 (15 U.S.C. 78m(a), 78o(d)) or section 6104 of the Internal Revenue Code of 1986?:

Yes  No

(iv) Does your business or organization maintain a record in the System for Award Management ([www.SAM.gov](http://www.SAM.gov))?

Yes  No

(v) If you have indicated "Yes" for paragraph (ii) **and** "No" for paragraph (iii) and (iv) above, provide the names and total compensation\* of your five most highly compensated executives\*\* for the preceding completed fiscal year.

1. Name: \_\_\_\_\_  
Amount: \_\_\_\_\_

2. Name: \_\_\_\_\_  
Amount: \_\_\_\_\_

3. Name: \_\_\_\_\_  
Amount: \_\_\_\_\_

4. Name: \_\_\_\_\_  
Amount: \_\_\_\_\_

5. Name: \_\_\_\_\_  
Amount: \_\_\_\_\_

The information provided above is true and accurate as of the date of execution of the referenced Subcontract or Sub-Task Order. Annual certification is required for information provided in paragraph v) above.

\*“Total compensation” means the cash and noncash dollar value earned by the executive during the Subcontractor’s preceding fiscal year and includes the following (for more information see 17 CFR 229.402(c)(2)):

(1) *Salary and bonus.*

(2) *Awards of stock, stock options, and stock appreciation rights.* Use the dollar amount recognized for financial statement reporting purposes with respect to the fiscal year in accordance with the Financial Accounting Standards Board’s Accounting Standards Codification (FASB ASC) 718, Compensation-Stock Compensation.

(3) *Earnings for services under non-equity incentive plans.* This does not include group life, health, hospitalization or medical reimbursement plans that do not discriminate in favor of executives, and are available generally to all salaried employees.

(4) *Change in pension value.* This is the change in present value of defined benefit and actuarial pension plans.

(5) *Above-market earnings on deferred compensation which is not tax-qualified.*

(6) Other compensation, if the aggregate value of all such other compensation (e.g., severance, termination payments, value of life insurance paid on behalf of the employee, perquisites or property) for the executive exceeds \$10,000.

\*\*\*“Executive” means officers, managing partners, or any other employees in management positions

## **Z.7. REPRESENTATIONS AND CERTIFICATIONS**

Any representations and certifications submitted resulting in award of this Subcontract are hereby incorporated either in full text or by reference, and any updated representations and certifications submitted thereafter are incorporated by reference and made a part of this Subcontract with the same force and effect as if they were incorporated by full text. By signing this Subcontract, the Subcontractor hereby certifies that as of the time of award of this Subcontract: (1) the Subcontractor, or its principals, is not debarred, suspended or proposed for debarment or declared ineligible for award by any Federal agency; (2) no Federal appropriated funds have been paid or will be paid to any person for influencing or attempting to influence an officer or employee of any agency, a Member of Congress, an officer or employee of Congress, or an employee of a Member of Congress on its behalf in connection with awarding the contract or this Subcontract; and (3) no changes have occurred to any other representations and certifications made by the Subcontractor resulting in award of this subcontract. The Subcontractor agrees to promptly notify Chemonics in writing of any changes occurring at any time during performance of this Subcontract to any representations and certifications submitted by the Subcontractor.

[End of Subcontract]

**Annex 1      Cover Letter**

[Offeror: Insert date]

Name of Point of Contact for RFP: Marina Petrovic  
Grants & SAF Specialist  
DHP of the Municipality of Knjazevac  
Chemonics International Inc.  
Serbia Better Energy Activity  
Dubljanska 8, Belgrade

Reference:      Request for Proposals 02 Public Utility Enterprise DHP Knjazevac

Subject:          [Offeror: Insert name of your organization]'s technical and cost proposals

Dear Mr./Mrs. Marina Petrovic:

[Offeror: Insert name of your organization] is pleased to submit its proposal in regard to the above-referenced request for proposals. For this purpose, we are pleased to provide the information furnished below:

Name of Organization's Representative \_\_\_\_\_

Name of Offeror \_\_\_\_\_

Type of Organization \_\_\_\_\_  
Taxpayer Identification Number \_\_\_\_\_  
UEI Number \_\_\_\_\_  
Address \_\_\_\_\_  
Address \_\_\_\_\_  
Telephone \_\_\_\_\_  
Fax \_\_\_\_\_  
E-mail \_\_\_\_\_

As required by section I, I.7, we confirm that our proposal, including the cost proposal will remain valid for 90 calendar days after the proposal deadline

We are further pleased to provide the following annexes containing the information requested in the RFP.:  
[Offerors: It is incumbent on each offeror to clearly review the RFP and its requirements. It is each offeror's responsibility to identify all required annexes and include them]

- I. Copy of registration or incorporation in the public registry, or equivalent document from the government office where the offeror is registered.
- II. Copy of company tax registration, or equivalent document.
- III. Copy of trade license, or equivalent document.
- IV. Evidence of Responsibility Statement.

Sincerely yours,

\_\_\_\_\_  
Signature

[Offeror: Insert name of your organization's representative]

[Offeror: Insert name of your organization]

## **Annex 2      Guide to Creating a Financial Proposal for a Fixed Price Subcontract**

The purpose of this annex is to guide offerors in creating a budget for their cost proposal. Because the subcontract will be funded under a United States government-funded project, it is important that all offerors' budgets conform to this standard format. It is thus strongly recommended that offerors follow the steps described below.

**Under no circumstances may cost information be included in the technical proposal.** No cost information or any prices, whether for deliverables or line items, may be included in the technical proposal. Cost information must only be shown in the cost proposal.

**Step 1:** Design the technical proposal. Offerors should examine the market for the proposed activity and realistically assess how they can meet the needs as described in this RFP, specifically in section II. Offerors should present and describe this assessment in their technical proposals.

**Step 2:** Determine the basic costs associated with each deliverable. Offerors should consider best estimate of the costs associated with each deliverable, which should include labor and all non-labor costs, e.g. other direct costs, such as fringe, allowances, travel and transport, etc.

**Step 3:** Create a budget for the cost proposal. Each offeror must create a budget using a spreadsheet program compatible with MS Excel. The budget period should follow the technical proposal period. A sample budget is shown on the following page. All items and services must be clearly labeled and include the total offered price. The detailed budget must show major line items, including, for example:

1. Salaries
2. Indirect costs
3. Any other costs applicable to the work
4. DBA – see clause I. 11

All cost information must be expressed in Serbian dinars (RSD)

**Step 4:** Write Budget Narrative. The spreadsheets shall be accompanied by written notes in MS Word that explain each cost line item and the assumption why a cost is being budgeted as well as how the amount is reasonable. Supporting information must be provided in sufficient detail to allow for a complete analysis of each cost element or line item. Chemonics reserves the right to request additional cost information if the evaluation committee has concerns of the reasonableness, realism, or completeness of an offeror's proposed cost.

If it is an offeror's regular practice to budget indirect rates, e.g. overhead, fringe, G&A, administrative, or other rate, Offerors must explain the rates and the rates' base of application in the budget narrative. Chemonics reserves the right to request additional information to substantiate an Offeror's indirect rates.

### Sample Budget

Offerors should revise the budget line items accordingly in response to the technical and cost requirements of this RFP.

The offerors must include price per deliverable listed in the section II.3

Deliverable Number	Deliverable Name	*Price RSD
1.	Project documentation for Execution design for 16 thermal substations of DHP Knjazevac	

\*VAT should not be included in the cost proposal

Design, Production, and Distribution of Communications Materials to District Courts			
Deliverable	Base	Rate	Total
<b>Deliverable No. 1: Draft Communication Materials</b>			
Design Specialist (daily rate)	6	\$400	\$2,400
Operations Manager (daily rate)	3	\$500	\$1,500
Software Lisence	1	\$1,500	\$1,500
<i>Total, Deliverable 1</i>			\$5,400
<b>Deliverable No. 2: Printed Communication Materials</b>			
Design Specialist (daily rate)	3	\$400	\$1,200
Operations Manager (daily rate)	2	\$500	\$1,000
Pamphlet Paper	500	\$2	\$1,000
Printing Ink	1	\$1,000	\$1,000
<i>Total, Deliverable 2</i>			\$4,200
<b>Deliverable No. 3: Proof of Distribution of Materials to Districts 1-4</b>			
Operations Manager (daily rate)	1	\$500	\$500
Logistics Manager (daily rate)	4	\$200	\$800
Truck Rental and Fuel	1	\$2,000	\$2,000
Per Diem for Logistics Manager	3	\$75	\$225
<i>Total, Deliverable 3</i>			\$3,525
<b>Deliverable No. 4: Proof of Distribution of Materials to Districts 5-8</b>			
Operations Manager (daily rate)	1	\$500	\$500
Logistics Manager (daily rate)	4	\$200	\$800
Truck Rental and Fuel	1	\$2,000	\$2,000
Per Diem for Logistics Manager	3	\$75	\$225
<i>Total, Deliverable 4</i>			\$3,525
<b>Grand Total</b>			<b>\$16,650</b>

## Annex 3 Required Certifications

### EVIDENCE OF RESPONSIBILITY

#### 1. Offeror Business Information

**Company Name:** Full Legal Name

**Address:** Address

**UEI Number:** Enter the Unique Entity Identifier (UEI number) assigned to the company / (Instructions If Offeror does not have a UEI number and is unable to obtain one before proposal submission deadline, Offeror shall include a statement in their Evidence of Responsibility Statement noting their intention to register for a UEI number should it be selected as the successful offeror or explaining why registration for a UEI number is not applicable or not possible. Additional guidance on obtaining a UEI number is available upon request.)

#### 2. Authorized Negotiators

Company Name proposal for Proposal Name may be discussed with any of the following individuals. These individuals are authorized to represent Company Name in negotiation of this offer in response to **RFP No. 02**

List Names of Authorized signatories

These individuals can be reached at Company Name office:

Address

Telephone/Fax

Email address

#### 3. Adequate Financial Resources

Company Name has adequate financial resources to manage this contract, as established by our audited financial statements (OR list what else may have been submitted) submitted as part of our response to this proposal.

If the offeror is selected for an award valued at \$30,000 or above, and is not exempted based on a negative response to Section 3(a) below, any first-tier subaward to the organization may be reported and made public through FSRS.gov in accordance with The Transparency Acts of 2006 and 2008. Therefore, in accordance with FAR 52.240-10 and 2CFR Part170, if the offeror positively certifies below in Sections 3.a and 3.b and negatively certifies in Sections 3.c and 3.d, the offeror will be required to disclose to Chemonics for reporting in accordance with the regulations, the names and total compensation of the organization's five most highly compensated executives. By submitting this proposal, the offeror agrees to comply with this requirement as applicable if selected for a subaward.

In accordance with those Acts and to determine applicable reporting requirements, **Company Name** certifies as follows:

- a) In the previous tax year, was your company's gross income from all sources above \$300,000?

Yes  No

- b) In your business or organization's preceding completed fiscal year, did your business or organization (the legal entity to which the DUNS/UEI number belongs) receive (1) 80 percent or more of its annual gross revenues in U.S. federal contracts, subcontracts, loans, grants, subgrants, and/or cooperative agreements; **and** (2) \$25,000,000 or more in annual gross revenues from U.S. federal contracts, subcontracts, loans, grants, subgrants, and/or cooperative agreements?:

Yes  No

- c) Does the public have access to information about the compensation of the executives in your business or organization (the legal entity to which the DUNS/UEI number it provided belongs) through periodic reports filed under section 13(a) or 15(d) of the Securities Exchange Act of 1934 (15 U.S.C. 78m(a), 78o(d)) or section 6104 of the Internal Revenue Code of 1986? (FFATA § 2(b)(1)):

Yes  No

- d) Does your business or organization maintain an active registration in the System for Award Management ([www.SAM.gov](http://www.SAM.gov))?

Yes  No

#### 4. Ability to Comply

**Company Name** is able to comply with the proposed delivery of performance schedule having taken into consideration all existing business commitments, commercial as well as governmental.

#### 5. Record of Performance, Integrity, and Business Ethics

**Company Name** record of integrity is (Instructions: Offeror should describe their record. Text could include example such as the following to describe their record: "outstanding, as shown in the Representations and Certifications. We have no allegations of lack of integrity or of questionable business ethics. Our integrity can be confirmed by our references in our Past Performance References, contained in the Technical Proposal.")

#### 6. Organization, Experience, Accounting and Operational Controls, and Technical Skills

(Instructions: Offeror should explain their organizational system for managing the subcontract, as well as the type of accounting and control procedure they have to accommodate the type of subcontract being considered.)



## 7. Equipment and Facilities

(Instructions: Offeror should state if they have necessary facilities and equipment to carry out the contract with specific details as appropriate per the subcontract SOW.)

## 8. Eligibility to Receive Award

(Instructions: Offeror should state if they are qualified and eligible to receive an award under applicable laws and regulation and affirm that they are not included in any list maintained by the US Government of entities debarred, suspended or excluded for US Government awards and funding. The Offeror should state whether they have performed work of similar nature under similar mechanisms for USAID. )

## 9. Commodity Procurement

(Instructions: If the Offeror does not have the capacity for commodity procurements - delete this section. If the Offeror does have the capacity, the Offeror should state their qualifications necessary to support the proposed subcontract requirements.)

## 10. Cognizant Auditor

(Instructions: Offeror should provide Name, address, phone of their auditors – whether it is a government audit agency, such as DCAA, or an independent CPA.)

## 11. Acceptability of Contract Terms

(Instructions: Offeror should state its acceptance of the proposed contract terms.)

## 12. Recovery of Vacation, Holiday and Sick Pay

(Instructions: Offeror should explain whether it recovers vacation, holiday, and sick leave through a corporate indirect rate (e.g. Overhead or Fringe rate) or through a direct cost. If the Offeror recovers vacation, holiday, and sick leave through a corporate indirect rate, it should state in this section the number of working days in a calendar year it normally bills to contracts to account for the vacation, holiday, and sick leave days that will not be billed directly to the contract since this cost is being recovered through the corporate indirect rate.)

## 13. Organization of Firm

(Instructions: Offeror should explain how their firm is organized on a corporate level and on practical implementation level, for example regionally or by technical practice.)

Signature: \_\_\_\_\_

Name: \_\_\_\_\_

*One of the authorized negotiators listed in Section 2 above should sign*

Title: \_\_\_\_\_

Date: \_\_\_\_\_

## Subcontractor Size Self-Certification Form

**Reference Number:** [enter the funding agency's solicitation or contract number]

**Project Name:** [enter full name of project]

**Primary NAICS Code:** [enter the [NAICS](#) code that best describes the work being performed under the subcontract. i.e: for technical assistance provision use 541990 or management consulting use 541611. For HHE use 484210 and for GIS use 541360. The NAICS codes most commonly used by Chemonics is 541611, 541618, 541620, 541990]

---

**Company Name:** Full legal name

**Address:** Street address

**City, State, Zip:** City, State Zip

**DUNS/UEI Number:** [enter the [Data Universal Numbering System \(DUNS\)](#) Unique Entity Identifier (UEI number) here. Subcontractors must have a DUNS/UEI, unless exempted, as a part of receiving a subcontract with Chemonics]

**Contact Person:** Name, Title

**Contact Phone Number:** (555) 555-5555

---

### Type of Entity

If you have difficulty ascertaining the business size status, please refer to SBA's website ([www.sba.gov/size](http://www.sba.gov/size)) or contact your local SBA office.

Small Business  Large Business  Nonprofit/Educational  Government  Non-US

If "Small Business" is checked above, and if applicable, please identify any additional small business designations under which the company qualifies. You may wish to review the definitions for the below categories in the Federal Acquisition Regulation 19.7 or 52.219-8 ([www.acquisition.gov/far/](http://www.acquisition.gov/far/)) to determine applicability.

<input type="checkbox"/> Small Disadvantaged Business	<input type="checkbox"/> 8(a)
<input type="checkbox"/> HUBZone	<input type="checkbox"/> Woman Owned Small Business
<input type="checkbox"/> Veteran Owned	<input type="checkbox"/> Service Disabled Veteran Owned
<input type="checkbox"/> Alaskan Native Corporation	<input type="checkbox"/> Indian Tribe

By signature below, I hereby certify that the business type and designation indicated above is true and accurate as of the date of execution of this document, and I further understand that under 15 U.S.C. 645(d), any person who misrepresents a business' size status shall (1) be punished by a fine, imprisonment, or both; (2) be subject to administrative remedies; and (3) be ineligible for participation in programs conducted under the authority of the Small Business Act.

---

Signature and Title (required)

---

Date

\*\*\*\*\*CHEMONICS INTERNAL USE ONLY\*\*\*\*\*  
HUBZone Status has been verified in the [System for Award Management database](#) or [Dynamic Small Business Database Search](#) as of \_\_\_/\_\_\_/\_\_\_ conducted by: \_\_\_\_\_.

**FEDERAL FUNDING ACCOUNTABILITY AND TRANSPARENCY ACT (FFATA)  
SUBAWARD REPORTING QUESTIONNAIRE AND CERTIFICATION**

**Prime Contract**

**Insert Prime Contract Name**

**Insert Prime Contract Number/Task Order Number**

**Subcontractor Data**

**Insert Subcontractor Name**

**Insert Subcontractor AddressLine1**

**Insert Subcontractor AddressLine2**

**Insert Subcontractor City, Insert Subcontractor State in USA, or Province/Other**

**Insert Subcontractor Zipcode or PostalCode Insert Subcontractor Country**

**Subcontract Number: INSERT SUBCONTRACT NUMBER**

**Start Date: INSERT SUBCONTRACT START DATE**

**Subcontract Value: INSERT SUBCONTRACT VALUE**

A. In the previous tax year, was your company's gross income from all sources **under** \$300,000?

Yes  No

B. If "No", please provide the below information and answer the remaining questions.

(i) **Subcontractor DUNS/UEI Number: Insert DUNS/UEI on record**

(ii) In your business or organization's preceding completed fiscal year, did your business or organization (the legal entity to which the DUNS/UEI number belongs) receive (1) 80 percent or more of its annual gross revenues in U.S. federal contracts, subcontracts, loans, grants, subgrants, and/or cooperative agreements; and (2) \$25,000,000 or more in annual gross revenues from U.S. federal contracts, subcontracts, loans, grants, subgrants, and/or cooperative agreements?:

Yes  No

(iii) Does the public have access to information about the compensation of the executives in your business or organization (the legal entity to which the DUNS/UEI number it provided belongs) through periodic reports filed under section 13(a) or 15(d) of the Securities Exchange Act of 1934 (15 U.S.C. 78m(a), 78o(d)) or section 6104 of the Internal Revenue Code of 1986?:

Yes  No

(iv) Does your business or organization maintain a record in the System for Award Management ([www.SAM.gov](http://www.SAM.gov))?

Yes  No

(v) If you have indicated “Yes” for paragraph (ii) **and** “No” for paragraph (iii) and (iv) above, provide the names and total compensation\* of your five most highly compensated executives\*\* for the preceding completed fiscal year.

1. Name: \_\_\_\_\_  
Amount: \_\_\_\_\_

2. Name: \_\_\_\_\_  
Amount: \_\_\_\_\_

3. Name: \_\_\_\_\_  
Amount: \_\_\_\_\_

4. Name: \_\_\_\_\_  
Amount: \_\_\_\_\_

5. Name: \_\_\_\_\_  
Amount: \_\_\_\_\_

By signature below, I hereby certify that the information provided above is true and accurate as of the date of execution of this document, and I further understand that annual certification is required for information provided in paragraph (v) above.

\_\_\_\_\_  
Signature and Title (required)

\_\_\_\_\_  
Date

\*“Total compensation” means the cash and noncash dollar value earned by the executive during the Subcontractor’s preceding fiscal year and includes the following (for more information see 17 CFR 229.402(c)(2)):

(1) *Salary and bonus.*

(2) *Awards of stock, stock options, and stock appreciation rights.* Use the dollar amount recognized for financial statement reporting purposes with respect to the fiscal year in accordance with the Financial Accounting Standards Board’s Accounting Standards Codification (FASB ASC) 718, Compensation-Stock Compensation.

(3) *Earnings for services under non-equity incentive plans.* This does not include group life, health, hospitalization or medical reimbursement plans that do not discriminate in favor of executives, and are available generally to all salaried employees.

(4) *Change in pension value.* This is the change in present value of defined benefit and actuarial pension plans.

(5) *Above-market earnings on deferred compensation which is not tax-qualified.*

(6) Other compensation, if the aggregate value of all such other compensation (*e.g.*, severance, termination payments, value of life insurance paid on behalf of the employee, perquisites or property) for the executive exceeds \$10,000.

\*\*\*"Executive" means officers, managing partners, or any other employees in management positions.

## **Annex 4**

### **/UEI and SAM Registration Guidance**

#### **What is an UEI Number?**

The Unique Entity Identifier, or the UEI, is the official name of the "new, non-proprietary identifier" that will replace the DUNS number. The UEI will be requested in, and assigned by, the System for Award Management (SAM.gov). Businesses and organizations who receive funding from the US government will have to use a Unique Entity Identifier (UEI) created in SAM.gov. The UEI number helps the USG to identify companies.

#### **Why am I being requested to obtain a /UEI number?**

U.S. law – in particular the Federal Funding Accountability and Transparency Act of 2006 (Pub.L. 109-282), as amended by section 6202 of the Government Funding Transparency Act of 2008 (Pub.L. 110-252) - make it a requirement for all entities doing business with the U.S. Government to be registered, currently through the System for Award Management, a single, free, publicly- searchable website that includes information on each federal award. As part of this reporting requirement, prime contractors such as Chemonics must report information on qualifying subawards as outlined in FAR 52.204-10 and 2CFR Part 170. Chemonics is required to report subcontracts with an award valued at greater than or equal to \$30,000 under a prime contract and subawards under prime grants or prime cooperative agreements obligating funds of \$25,000 or more, whether U.S. or locally based. Because the U.S. Government uses UEI numbers to uniquely identify businesses and organizations, Chemonics is required to enter subaward data with a corresponding UEI number.

#### **Is there a charge for obtaining a UEI number?**

No. Obtaining a UEI number is absolutely free for all entities doing business with the Federal government. This includes current and prospective contractors, grantees, and loan recipients.

#### **How do I obtain a UEI number?**

UEI numbers can be obtained online at SAM.gov.

#### **What information will I need to obtain a UEI number?**

To request a UEI number, you will need to provide the following information:

- Legal name and structure
- Tradestyle, Doing Business As (DBA), or other name by which your organization is commonly recognized

- Physical address, city, state and Zip Code
- Mailing address (if separate)
- Telephone number
- Contact name
- Number of employees at your location
- Description of operations and associated code (SIC code found at <https://www.osha.gov/pls/imis/sicsearch.html>)
- Annual sales and revenue information
- Headquarters name and address (if there is a reporting relationship to a parent corporate entity)

### **How long does it take to obtain a UEI number?**

The UEI number is issued immediately upon completion of the request process.

### **Are there exemptions to the /UEI number requirement?**

There may be exemptions under specific prime contracts, based on an organization's previous fiscal year income when selected for a subcontract award, or Chemonics may agree that registration is impractical in certain situations. Organizations may discuss these options with the Chemonics representative.

### **What is CCR/SAM?**

Central Contractor Registration (CCR)—which collected, validated, stored and disseminated data in support of agency acquisition and award missions—was consolidated with other federal systems into the System for Award Management (SAM). SAM is an official, free, U.S. government-operated website. There is NO charge to register or maintain your entity registration record in SAM.

### **When should I register in SAM?**

While registration in SAM is not required for organizations receiving a grant under contract, subcontract or cooperative agreement from Chemonics, Chemonics requests that partners register in SAM if the organization meets the following criteria requiring executive compensation reporting in accordance with the FFATA regulations referenced above. SAM.gov registration allows an organization to directly report information and manage their organizational data instead of providing it to Chemonics. Reporting on executive compensation for the five highest paid executives is required for a qualifying subaward if in your business or organization's preceding completed fiscal year, your business or organization (the legal entity to which the UEI number belongs):

- (1) received 80 percent or more of its annual gross revenues in U.S. federal contracts, subcontracts, loans, grants, subgrants, and/or cooperative agreements; **and**
- (2) \$25,000,000 or more in annual gross revenues from U.S. federal contracts, subcontracts, loans, grants, subgrants, and/or cooperative agreements; **and,**
- (3) The public have **does not** have access to information about the compensation of the executives in your business or organization (the legal entity to which the UEI number it provided belongs) through periodic reports filed under section 13(a) or 15(d) of the Securities Exchange Act of 1934 (15 U.S.C. 78m(a), 78o(d)) or section 6104 of the US Internal Revenue Code of 1986.

If your organization meets the criteria to report executive compensation, the following sections of this document outline the benefits of and process for registration in SAM.gov. Registration may be initiated at <https://www.sam.gov>. There is NO fee to register for this site.

### **Why should I register in SAM?**

Chemionics recommends that partners register in SAM to facilitate their management of organizational data and certifications related to any U.S. federal funding, including required executive compensation reporting. Executive compensation reporting for the five highest paid executives is required in connection with the reporting of a qualifying subaward if:

- a. In your business or organization's preceding completed fiscal year, your business or organization (the legal entity to which the UEI number belongs) received (1) 80 percent or more of its annual gross revenues in U.S. federal contracts, subcontracts, loans, grants, subgrants, and/or cooperative agreements; and (2) \$25,000,000 or more in annual gross revenues from U.S. federal contracts, subcontracts, loans, grants, subgrants, and/or cooperative agreements; and,
- b. The public have does not have access to information about the compensation of the executives in your business or organization (the legal entity to which the UEI number it provided belongs) through periodic reports filed under section 13(a) or 15(d) of the Securities Exchange Act of 1934 (15 U.S.C. 78m(a), 78o(d)) or section 6104 of the Internal Revenue Code of 1986.

### **What benefits do I receive from registering in SAM?**

By registering in SAM, you gain the ability to bid on federal government contracts. Your registration does not guarantee your winning a government contract or increasing your level of business. Registration is simply a prerequisite before bidding on a contract. SAM also provides a central storage location for the registrant to supply its information, rather than with each federal agency or prime contractor separately. When information about your business changes, you only need to document the change in one place for every federal government agency to have the most up-to-date information.

### **How do I register in SAM?**

Follow the step-by-step guidance for registering in SAM for assistance awards (under grants/cooperative agreements) at: [https://www.sam.gov/sam/transcript/Quick\\_Guide\\_for\\_Grants\\_Registrations.pdf](https://www.sam.gov/sam/transcript/Quick_Guide_for_Grants_Registrations.pdf)

Follow the step-by-step guidance for contracts registrations at:  
[https://www.sam.gov/sam/transcript/Quick\\_Guide\\_for\\_Contract\\_Registrations.pdf](https://www.sam.gov/sam/transcript/Quick_Guide_for_Contract_Registrations.pdf)

*You must have a UEI number in order to begin either registration process.*

If you already have the necessary information on hand (see below), the online registration takes approximately one hour to complete, depending upon the size and complexity of your business or organization.

### **What data is needed to register in SAM?**

SAM registrants are required to submit detailed information on their company in various categories. Additional, non-mandatory information is also requested. Categories of required and requested information include:

\* General Information - Includes, but is not limited to, UEI number, CAGE Code, company name, Federal Tax Identification Number (TIN), location, receipts, employee numbers, and web site address.

\* Corporate Information - Includes, but is not limited to, organization or business type and SBA-defined socioeconomic characteristics.

\* Goods and Services Information - Includes, but is not limited to, NAICS code, SIC code, Product Service (PSC) code, and Federal Supply Classification (FSC) code.

\* Financial Information - Includes, but is not limited to, financial institution, American Banking Association (ABA) routing number, account number, remittance address, lock box number, automated clearing house (ACH) information, and credit card information.

\* Point of Contact (POC) Information - Includes, but is not limited to, the primary and alternate points of contact and the electronic business, past performance, and government points of contact. \* Electronic Data Interchange (EDI) Information\* - Includes, but is not limited to, the EDI point of contact and his or her telephone, e-mail, and physical address. (\*Note: EDI Information is optional and may be provided only for businesses interested in conducting transactions through EDI.)



Annex 5



РЕПУБЛИКА СРБИЈА  
МИНИСТАРСТВО СПОЉНИХ ПОСЛОВА  
Дипломатски протокол

Број: 3-9/22

Датум: 1. јануар 2022. године

НАДЛЕЖНИМ ОРТАНИМА РЕПУБЛИКЕ СРБИЈЕ

Премамет: Потврда о ослобађању од ПДВ и акциза;  
Извршни партнер USAID *Chemonics International, Inc – Serbia Energy Security Activity – Better Energy – Bolja energija*

У складу са одредбама чл. 24. Закона о порезу на додату вредност Републике Србије, као и одредбама чл. 19. Закона о акцизама Републике Србије, а на основу Споразума о економској, техничкој и другој сродној сарадњи са САД (USAID),

**ПОТВРЂУЈЕ СЕ**

1. да је Канцеларија извршног партнера USAID – *Chemonics International, Inc – Serbia Energy Security Activity – Better Energy – Bolja energija* у Београду ослобођена од плаћања пореза на додату вредност и акциза за набавке роба и услуга.

2. да су носиоци сервисних личних карата Канцеларије извршног партнера USAID – *Chemonics International, Inc – Serbia Energy Security Activity – Better Energy – Bolja energija* у Београду ослобођени од плаћања пореза на додату вредност и акциза за увоз возила и личних селдбених ствари. Ослобађање се односи и на трошкове изнајмљивања објеката намењених за смештај особља.

**НАПОМЕНА У ВЕЗИ СА АКЦИЗНОМ РОБОМ:**

Увоз акцизне робе (све врсте моторног бензина, све врсте дизел горива, течни нафтни гас за погон моторних возила; алкохолна пића и лувански производи) у Републику Србију, као и куповина акцизне робе на локалном тржишту у Републици Србији без плаћања ПДВ и акциза, ограничени су унапред утврђеним лимитима (или квотама). Имајући претходно у виду, куповина наведених производа на локалном тржишту може се извршити само у количинама наведеним у списку сачињеном од стране ДКП, који је потписан од стране шефа мисије и оверен печатом мисије, а затим наоверен у Дипломатском протоколу Министарства спољних послова потписом одговорног лица и печатом Министарства.

Потврда важи за календарску годину за коју се издаје.

Овом Потврдом престаје да важи Потврда број 3-9/21 од 1. јануара 2021. године.



ШЕФ ДИПЛОМАТСКОГ ПРОТОКОЛА

*Мирјана Јеремид*  
Мирјана Јеремид



1717 H Street, NW  
Washington, D.C. 20006  
T: 202.955.3300  
F: 202.955.3400  
chemonics.com

РЕПУБЛИКА СРБИЈА  
МИНИСТАРСТВО ФИНАНСИЈА

CENTRALA PORESKE UPRAVE  
Save Maškovića 3-5  
11000 Beograd, Srbija

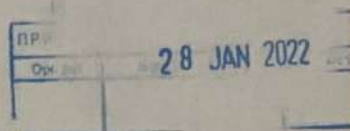

Predstavništvo Chemonics International Inc. Beograd  
Serbia Energy Security Activity- Better Energy - Bolja energija  
Njegoševa 11, Beograd

Poštovani,

Obaveštavamo Vas da u ime Agencije Sjedinjenih Američkih Drzava za međunarodni razvoj (USAID), Predstavništvo Chemonics International Inc. Beograd, sa sedištem u Beogradu, ulica Njegoševa 11, PIB 112646448, Matični br. 29028036 sprovodi projekat „Serbia Energy Security Activity- Better Energy - Bolja energija“.

Na osnovu Diplomatskog protokola Predstavništvo Chemonics International Inc. Beograd je ovlastio sledeća lica za izdavanje SNPDV i PPOPDV obrasca:

1. Daniel Berg, SAD pasoš 505595952,

2. Slobodan Perović, JMBG 2306976762028.

3. Igor Mandić, JMBG 0709973710175,

U prilogu Vam dostavljamo dokument kojim se potvrđuje da je poresko oslobodjenje predviđeno međunarodnim ugovorom odnosno Diplomatski protokol br. 3-9/22 od 01. januara 2022., izdatog od strane Ministarstva spoljnih poslova Republike Srbije.

S poštovanjem,

  
Daniel Berg, direktor projekta

Annex 6

**Terms of Reference**  
**With**  
**CONCEPT DESIGN of MODERNIZATION,**  
**AUTOMATION and SCADA SYSTEM of HEATING**  
**SUBSTATIONS in KNJAZEVCAC**

**Project task : procurement of project documentation**  
**(Main project design)**

(Including CONCEPT DESIGN PROJECT OF MODERNIZATION, AUTOMATION AND SCADA OF HEATING SUBSTATIONS of DHC KNJAŽEVAC)

Contents:

1. Terms of reference
2. Technical description
  - 2.1 Technical description of control system at level of heating substation
  - 2.2 Technical description of SCADA system
  - 2.3 Technical description of communication with heating substations
3. Technical conditions for performance of works

## **1. Terms of reference:**

The Terms of Reference includes the preparation of technical project documentation for the entire mechanical and electrical phase of heating substations of DHS Knjazevac.

The project must consist of:

1. Mechanical part
2. Electrical energy and automation part
3. Part containing description of work and SCADA solution

The technical project documentation that is the object of procurement must be done at the level of execution project and must contain all the parts in detail as implied by the execution project:

1. General part of the project
2. Numerical documentation and calculations
3. Graphic documentation
4. Bill of quantities

The mechanical part must include all the necessary mechanical and technical details related to thermo-mechanical armature of the heating substations.

The part containing electrical energy and automation must include the substation power supply system, all the circulation pumps, measuring, control and communication equipment necessary for the operation of the heating substation.

The SCADA system part must include a detailed description of the SCADA system, control algorithms and communication equipment for remote connection of the central SCADA server with the heating substations.

What follows in the text is the concept design which serves as a basis for the execution project which is the object of procurement:

### **2. Technical description of the CONCEPT DESIGN:**

It is necessary to modernize, automate and optimize the operation of 16 heating substations supplying the heat energy to apartment buildings in Knjazevac. Automation with the remote control of the heating substations is necessary in order to achieve optimal delivery of the heat energy to the consumer.

Heat energy delivery to the consumer must be in accordance with the needs of the consumer, with the available quantity of energy in the system and with the outside temperature in real time. The heating substations located in the 16 buildings that are the object of the project do not have the equipment that would enable optimal delivery of heat energy, which leads to the incongruence

between the actual needs of the consumer and the quantity of energy delivery by the heating substation. This situation makes it impossible to use the system rationally, especially in the transition periods – more heat energy is delivered to the consumer than it is necessary and as a result, there is an increased consumption of fuel in the system. In addition to the increased cost, the increased fuel consumption also leads to the unnecessarily increased emission of combustion byproducts into the atmosphere. A detailed analysis of each of the 16 heat substations determined that each heat substation was equipped with dilapidated and defective mechanical and electrical elements (exchanger, circulating pumps, valves), and lacked measuring and control equipment and equipment for communication with the command center.

Concept design includes:

1. Concept design of functioning of each individual substation;
2. Concept design of functioning of the SCADA system with the system of communication towards all the substations;

### ***2.1. Technical description of control system at the level of the heat substation***

In the 17 heating substations it is necessary to design a system of control so that there is a possibility of remote monitoring and remote control of the heating substation. In the concept design there will be only a typical model of the substation with the description of all the elements necessary for a full automation. All substations demand similar equipment, the only difference being the number of individual elements and the size of elements. At the level of Execution Project each substation will be analyzed. Note that S4 substation is not included in this tender

The state of a typical substation after automation with all the elements is shown in the following two pictures that differ only in the number of the pumps on the secondary side.

## Podstanica sa jednom cirkulacionom pumpom

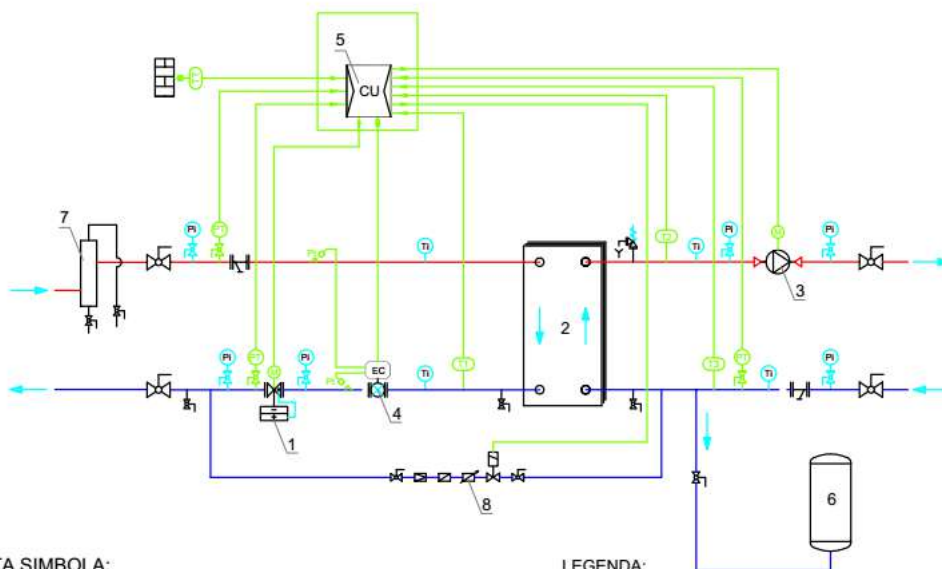

### LISTA SIMBOLA:

- REGULACIONI VENTIL SA ELEKTROMOTORNIM POGONOM
- ULTRAZVUČNI KALORIMETAR
- ODMULJNO-ODZRAČNI SUD
- LOPTASTI VENTIL
- ODVAJAČ PRLJAVŠTINE

- CIRKULACIONA PUMPA
- VENTIL SIGURNOSTI SA OPRUGOM
- NEPOVRATNI VENTIL
- UMANJIVAČ PRITISKA
- MERAČ PROTOKA VODE
- TERMOMETAR
- MANOMETAR
- TRANSMITER TEMPERATURE SA SENZOROM U ČAURI
- SPOLJNI SENZOR

### LEGENDA:

1. REGULACIONI VENTIL SA EL. POGONOM
2. LEMLJENI RAZMENJIVAČ TOPLOTE
3. CIRKULACIONA PUMPA
4. ULTRAZVUČNI KALORIMETAR
5. KONTROLER
6. EKSPANZIONA POSUDA
7. ODZRAČNO-ODMULJNI LONAC
8. VODOMER

TT - SPOLJNI SENZOR TEMPERATURE  
T1, T2, T3 - CEVNI SENZOR TEMPERATURE

## Podstanica sa dve izdvojene cirkulacione pumpe

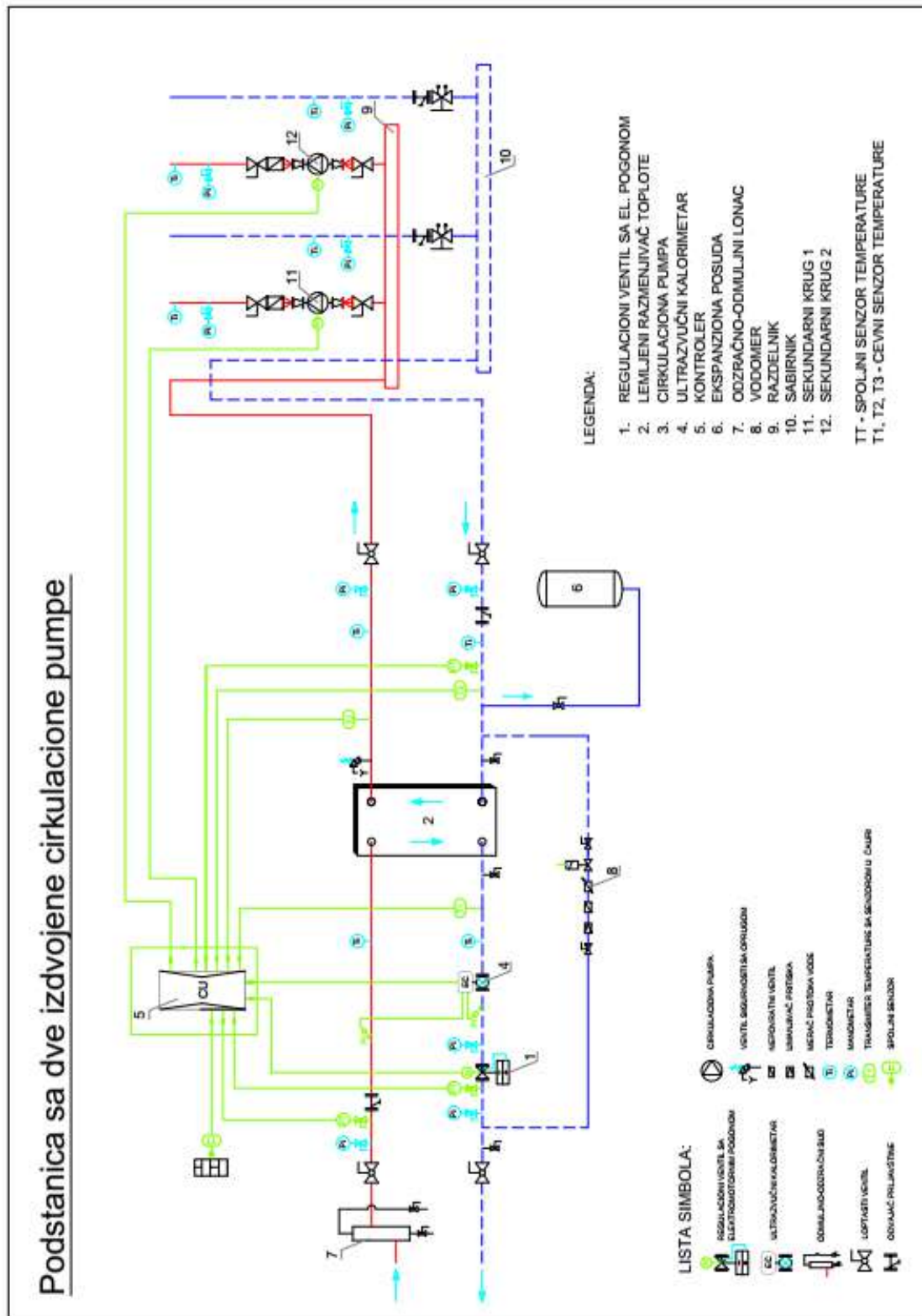



Real-time automatic control equipment according to the required parameters, as well as remote control equipment consists of the following elements:

- Control valve with electric motor drive
- Solder heat exchanger
- Circulation pump
- Ultrasonic calorimeter
- Controller
- Water meter
- Divider
- Busbar
- Tubular temperature sensor
- Communication modem with antenna

The combined valve should be a flow regulator with a mechanical flow limiting function and an additional electric drive (actuator). The valve should be compactly designed - differential pressure regulator and valve with electric drive in the same housing - "Combi valve". The desired flow is adjusted by positioning the control valve. Flow limitation is achieved by limiting the movement of the control valve.

The equipment intended for automatic control is placed in the distribution cabinet of the automation equipment of the heating substation. The same distribution cabinet must also contain switching and protection equipment, through which the pumps and motor actuators of the valve are supplied, as well as other electricity consumers in the heating substation. The controller must have the installed software for optimal local control of the heating substation as well as the communication software for communication with the central control server (SCADA server). Control of the heating substation is realized according to the algorithm which ensures that the heating substation delivers an optimal quantity of heat energy that suits the actual outside conditions, and the control of the heating substation can also be realized by force from the SCADA system. During regular operation it is desirable that the heating substation works according to the algorithm loaded in the local controller and that it receives key settings and information on the state of the distribution network through the SCADA system and remote control. Periodically (every 5 minutes), the heating substation also sends to the central system its status information, and in the case of alarm, the heat substation momentarily informs the central server about it.

The goal of the automation of the heating substations and the central system of monitoring and control of the heating substations is to increase energy efficiency, decrease direct energy losses caused by human factor in controlling critical processes of distribution of heat energy, improve general reliability and availability of the power plant, implement planned and predictive

maintenance, monitor energy efficiency of the plant and have an easy access to technical and financial analysis of the operation.

All the parts must meet the technical requirements and standards defined by technical specifications, with regards to all the technical characteristics related to material quality, quality of workmanship, dimensions and standards.

## ***2.2. Technical description of the SCADA system***

On the central command server there is an installed SCADA software with a database. The SCADA software is designed and realized according to the principle of MVC (Model –View- Control). The MVC model ensures that the SCADA software is based on and designed according to the real model of the process. The MODEL that serves as a basis for SCADA design completely describes a real process and contains all the parameters relevant for the functioning of the real system. The VIEW component ensures that SCADA system corresponds to the real situation in visual and synoptical terms. The CONTROL component ensures that scada system analytically corresponds to a business intelligence-logic which meets the requirements of optimal control of heating substations and ensures the control of communication between the central monitoring system and substations.

Model of functioning and organization of SCADA system communication

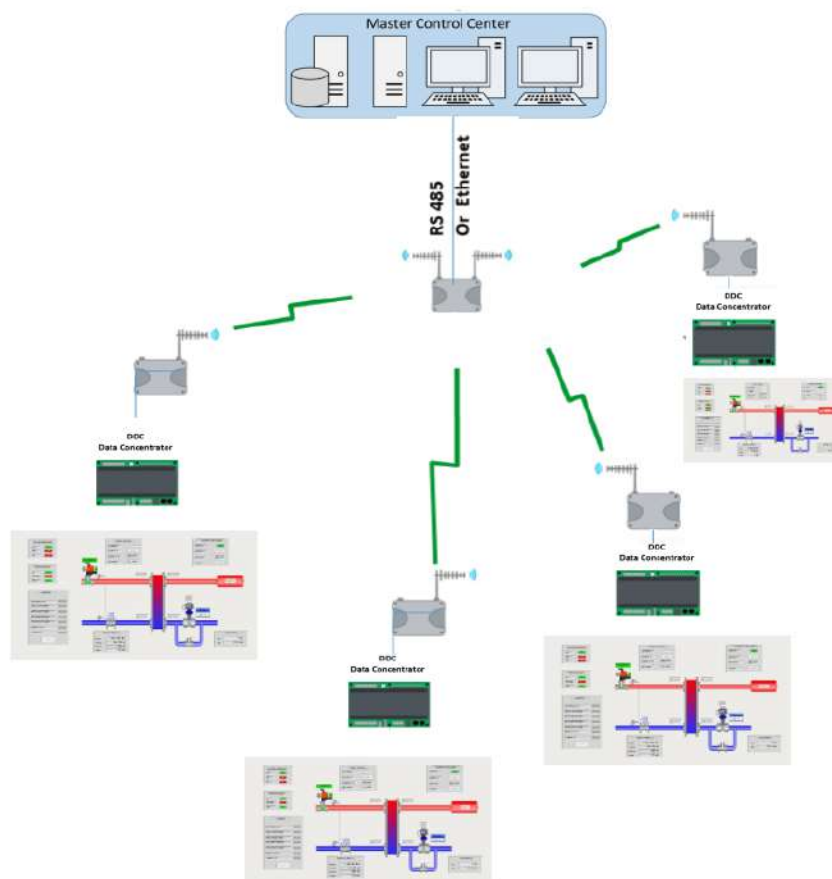

SCADA software is installed on a PC in the command center and communicates with all the heating substations via communication equipment. The data obtained from the heating substations are kept in the SCADA database, which is regularly copied and preserved according to the principles and rules of keeping data. SCADA is WEB-oriented software which communicates with substations via safe SSH protocols, and also enables a remote access to both the central server and each substation to authorized clients. As an integral part of SCADA system there has to be a GIS map of all the substations in the interface of the software. Through SCADA software it is possible to access each heating substation and read or set its parameters. In each substation it is also possible to monitor the graphs of temperature trends, operation regimes, cumulative quantity of delivered heat energy, momentary heat energy being delivered etc. The requirement SCADA software has to meet is the possibility of reading the state on the calorimeters and preparation for generating bills for consumers.

### 2.3. Technical description of the system of communication between heating substations and a central SCADA system

The system of communication is based on GPRS modems.

For the sake of GPRS communication it is necessary for each substation to be equipped with a communication router. The communication center also has to be equipped with a GPRS communication router. This kind of communication requires that each modem has its own GSM card with the Internet connection.

Model of communication via a GPRS modem is shown in the following picture.

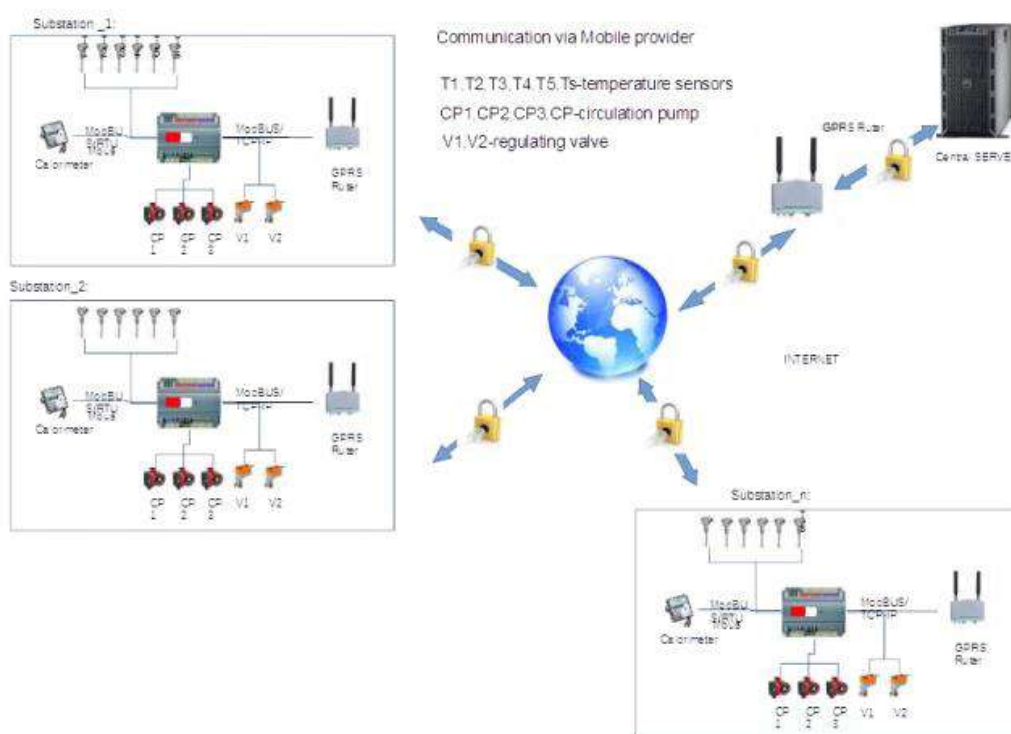

### 3. TECHNICAL CONDITIONS FOR PERFORMANCE OF WORKS

It is necessary to make a detailed insight into a real/existing state of mechanical equipment in all the heating substations and, according to it, to make Execution Projects for mechanical installations of the heating substation, in which sizing, calculation, selection of equipment, graphic documentation / drawings, technological scheme of mechanical installation of the substation will be performed and a complete project solution will be created.

Works on the automation of the substation include: replacement of mechanical elements in the substation (dirt traps, pressure regulators, safety valves, combi flow regulators ...) and installation of new ones, automation of all heating control circuits, installation of temperature sensors,

installation of pressure sensors in selected heating substations, replacement of the complete electrical installation and installation of a new substation distribution cabinet with an electronic controller, communication connection of the controller and heat meters and connection of the substation to the remote monitoring and control system.

It is necessary to make a detailed insight into the actual / existing condition of electrical installations and equipment in all thermal substations (power supply, route of electrical installations, disposition and dimensions of the existing distribution cabinet of the thermal substation, nominal current / power of circulation pumps, lighting, etc.) and, according to it, to make Projects for Construction of electric power installations of the thermal substation, in which sizing, calculation, selection of equipment will be performed and electrical schemes of electric power installations, control and communication of the thermal substation will be made and a complete project solution will be created.

For all thermal substations subject to automation, it is necessary to connect to the system for remote monitoring and management, to ensure:

All thermal substations, which are subject to automation, must be connected to the system of remote monitoring and control, so as to ensure:

- complete local automation (at the substation level): control of all control circuits (electric motor drives of valves), measurement of temperatures and pressures (in substations where the installation of pressure sensors is planned), control of circulation pumps, taking measurements from heat meters;
- graphical presentation of the technological scheme of the substation and display of all measured quantities and remote monitoring and management of each individual primary substation in the remote monitoring system;
- creating a database for distant monitoring and control system.

Software for SCADA application must ensure the following:

- Monitoring and control of heating substations that are the subject of works
- Schematic representation of the heat substation with the following elements: armature, measuring, regulating and safety equipment, circulating pumps,
- Display of current values of all measured / calculated quantities:

#### TEMPERATURE:

- supply water
- return water
- supply secondary side
- outside
- given by the slide diagram

PRESSURES:

- supply water
- return water
- supply secondary side

DATA FROM HEAT ENERGY MEASURING INSTRUMENTS

- Cumulative energy (MWh)
- Cumulative flow (m<sup>3</sup>)
- Momentary power (kW)
- Momentary flow (m<sup>3</sup>/h)

As well as the display of:

DATE and HOUR OF REAL TIME

DISPLAY OF WORKING CONDITION of:

- Circulation pump (in operation / not in operation)
- Combi valve with electric motor drive (opens / stops / closes)
- Display of the trend of the previously listed parameters for the selected date
- Tabular presentation of the previously listed parameters according to the order desired by the investor
- Report for the selected day / period with the display of all quantities from the tabular display.
- Access to parameters and the possibility that the parameters can be changed only by authorized persons
- Alarm conditions

**Table: List of heat substations DISTRICT HEATING SYSTEM KNJAZEVCAC**

podstanica	Adresa podstanice	Instalisana snaga	Dimenzija primara	Dimenzija sekundara	Kapacitet izmjenjivača	Dimenzija kalorimetra	Nominalni Protok	Dimenzija kombi ventila	kvs vrednost	protok pumpe grana 1	napor pumpe grana 1	protok pumpe grana 2	napor pumpe grana 2	
		kW	DN	DN	kW	DN	m3/h	DN	m3/h	m3/h	m	m3/h	m	
S1	Janka Katića br. 17	700 kW	DN100	DN125	700	DN65	25.00	65	50.0	16	3.8	12	3.4	
S2	Milana Punčića br. 1	200 kW	DN50	DN65	200	R5/4"	6.00	32	12.5	8.6	3	-	-	
S3	Milana Punčića br.3	200 kW	DN50	DN65	200	R5/4"	6.00	32	12.5	8.6	3	-	-	
S4	Kindergarten – excluded from the scope of work													
S5	Branka Radičevića br. 14	500 kW	DN65	DN100	500	DN50	15.00	50	25.0	10	5.4	7	3.4	
S6	Branka Radičevića br. 6	530 kW	DN65	DN100	530	DN65	25.00	65	50.0	23	6.5	-	-	
S7	Branka Radičevića br. 12	530 kW	DN65	DN100	530	DN65	25.00	65	50.0	23	6.5	-	-	
S8	Napredak br.75	450 kW	DN65	DN100	450	DN50	15.00	50	25.0	15	5.5	-	-	
S9	RGP	360 kW	DN65	DN80	360	DN50	15.00	50	25.0	15	6	-	-	
S10	Bobijeva br. 2	320 kW	DN65	DN80	320	R6/4"	10.00	40	20.0	13	4.5	-	-	
S11	Branka Radičevića br. 4	370 kW	DN65	DN80	370	DN50	15.00	50	25.0	12	4.5	3	1.5	
S12	Kopeckova	360 kW	DN65	DN80	360	DN50	15.00	50	25.0	10	6	7	4.5	
S13	Branka Radičevića br. 2	520 kW	DN80	DN100	520	DN65	25.00	65	50.0	23	9.8	-	-	
S14	Dom kulture	1100 kW	DN125	DN150	1100	DN80	40.00	80	80.0	47	12	-	-	
S15	O.Š."Vuk Karadžić"	800 kW	DN100	DN125	-	DN65	25.00	80	80.0	-	-	-	-	
S16	9-te brigade br. 15	750 kW	DN100	DN125	750	DN65	25.00	80	80.0	16	6	16	6	
S17	9-te brigade br. 19	650 kW	DN100	DN125	650	DN65	25.00	65	50.0	14	4	14	4	